

CONCRETE LIBRARY OF JSCE NO. 20, DECEMBER 1992  
**DESIGN CODE FOR STEEL-CONCRETE SANDWICH STRUCTURES**  
**- DRAFT -**

(Translation from the CONCRETE LIBRARY No.73 published by JSCE, July 1992)

JSCE Research Subcommittee on Steel-Concrete Sandwich Structures



Hajime OKAMURA, Chairman

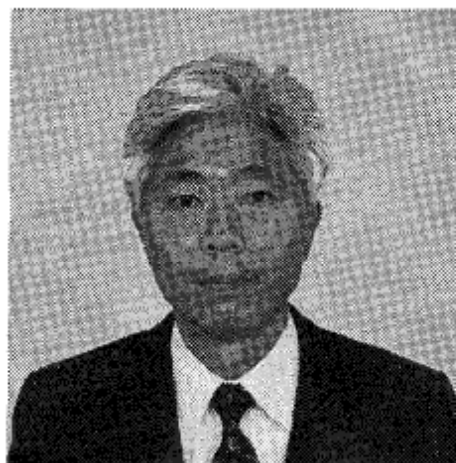

Yoshio KAKUTA, Vice Chairman

Members

Taisuke AKIMOTO  
Reiko AMANO  
Manabu FUJII  
Takashi IDEMITSU  
Shoji IKEDA  
Yoshiaki IMAI  
Hiroataka KAWANO  
Osamu KIYOMIYA  
Atsuhiko MACHIDA  
Naoki MASUI  
Shigeyuki MATSUI  
Susumu MATSUMOTO  
Koichi MINAMI  
Takashi MIURA

Hiroshi MUTSUYOSHI  
Kenji NAKAJIMA  
Hiroaki OKAMOTO  
Hiroshi SEKI  
Hiroshi SHIMA  
Toshiyuki SHIOYA  
Keiichiro SONODA  
Tomio TAMURA  
Tadaaki TANABE  
Tamon UEDA  
Hajime WAKUI  
Hiroshi YOKOTA  
Osamu YOSHIKAWA

Members from Sponsoring Organizations

Kazuo KOJIMA  
Yoji KUMAGAI

Ikuo SHIMIZU  
Toshiro UEMURA

## ABSTRACT

Design Code for Steel-Concrete Sandwich Structures, which has been drafted for the first time in Japan, is presented. The steel-concrete sandwich structure is defined as a composite structure in which core concrete is sandwiched by steel skin plates. The limit state design method is applied in the Design Code. The ultimate member capacities for axial, flexure and shear forces are newly given.

**Keywords:** design code, limit state design, composite structure, sandwich structure, flexural strength, shear strength, shear connector

---

**Hajime OKAMURA** is a professor in the Department of Civil Engineering at the University of Tokyo, Tokyo, Japan. His research interests include fatigue and shear of reinforced concrete members, durability design of reinforced concrete structures, application of FEM to reinforced concrete and development of high performance concrete.

---

**Yoshio KAKUTA** is a professor in the department of Civil Engineering at Hokkaido University, Sapporo, Japan. His research interests include cracking, shear and fatigue of reinforced concrete members, partial prestressed concrete and application of continuous fiber reinforcing materials to concrete structures.

---

## PREFACE

Because of the difficulty in the construction of steel-concrete sandwich structure and the lack of the established design and construction method, sandwich structures are rarely applied to the present structures despite its advantages in utilizing both steel and concrete structures. However, recent development of concrete which does not require compaction nor vibration has eliminated the construction difficulty. This together with the results of many studies on sandwich structures has paved way to an establishment of a rational design method and subsequently increase in the application of the sandwich structures.

Under these circumstances the Concrete Committee of the Japan Society of Civil Engineers, chaired by Prop Kazusuke Kobayashi at that time, was entrusted by Niju Kokaku Kozo Kenkyu-Kai (Association of Double Steel Skin Plates Structure) to establish design code for steel-concrete sandwich structures. As a consequence, a Research Committee on Steel-Concrete Sandwich Structures was set up by the Concrete Committee in 1990. The Committee spent two years deliberating the issue and conducting loading tests with large-scale specimens. It also examined design equations for ultimate member strengths and confirmed the competitiveness of sandwich structure to reinforced concrete structure by conducting a trial design of a submerged box structure.

This Concrete Library contains the Design Code for Steel-Concrete Sandwich Structures as well as reports on the research activities conducted by the Committee. The Design Code and the trial design were examined and approved by the Research Subcommittee and the Concrete Committee, while other research reports were submitted under full responsibility of respective authors. I hope that publication of the Design Code in the Concrete Library would promote adequate applications of the sandwich structures.

Finally I wish to express my gratitude to Prof Yoshio Kakuta, Vice-Chairman, Dr Tamon Ueda, Secretary for their dedications to the committee's work from the beginning until the publication of the Concrete Library. My appreciations also go to other committee members, especially Prop Keiichiro Sonoda, Dr Osamu Kiyomiya, Mr Naoki Masui, Dr Toshiyuki Shioya and Dr Hiroshi Shima whose contributions led to the success of the committee.

Hajime Okamura

Chairman of the Research Subcommittee on Steel-Concrete Sandwich Structures July 1992

## **TABLE OF CONTENTS**

### **DESIGN CODE FOR STEEL-CONCRETE SANDWICH STRUCTURES**

#### CHAPTER 1 GENERAL

##### 1.1 Scope

#### CHAPTER 2 GENERAL REQUIREMENTS

- 2.1 Design objectives
- 2.2 Design lifetime
- 2.3 Prerequisite of design
- 2.4 Design principles
- 2.5 Calculation of sectional forces and capacities
- 2.6 Safety factors
- 2.7 Documentation of design calculation

#### CHAPTER 3 DESIGN VALUES FOR MATERIALS

- 3.1 General
- 3.2 Concrete
- 3.3 Steel

#### CHAPTER 4 LOADS

- 4.1 General
- 4.2 Characteristic values for loads
- 4.3 Kinds of loads
  - 4.3.1 Loads during construction
  - 4.3.2 Loads during service

#### CHAPTER 5 STRUCTURAL ANALYSIS

- 5.1 General
- 5.2 Calculation of sectional forces

#### CHAPTER 6 LIMIT STATES

- 6.1 Ultimate limit states during construction
- 6.2 Serviceability limit states during construction
- 6.3 Ultimate limit states during service
  - 6.3.1 General
  - 6.3.2 Flexural moment and axial force
  - 6.3.3 Shear
  - 6.3.4 Torsion
- 6.4 Serviceability limit states during service
  - 6.4.1 Deflection and deformation

#### CHAPTER 7 STRUCTURAL DETAILS

- 7.1 Steel plates
- 7.2 Shear reinforcing steel plate
- 7.3 Corner connection

- 7.4 Shear connector
- 7.5 Minimum thickness of steel plate
- 7.6 minimum spacing of steel plates
- 7.7 Opening of steel plate

APPENDIX I \*  
AN EXAMPLE OF TRIAL DESIGN

APPENDIX II \*  
ON TREATMENT IN DESIGN OF STRESSES IN STEEL PLATES INDUCED DURING  
CONSTRUCTION OF STEEL-CONCRETE SANDWICH STRUCTURES

TREATMENT OF CONCRETE STRESSES INDUCED DURING CONSTRUCTION

ON ULTIMATE LIMIT STATES IN SHEAR  
- DERIVATION OF EQUATIONS FOR SHEAR CAPACITIES

METHOD OF DETERMINING AMOUNT OF SHEAR CONNECTORS  
SHEAR TRANSFER CAPACITIES OF SHEAR CONNECTORS  
CONSTRUCTION GUIDE FOR STEEL-CONCRETE SANDWICH STRUCTURES- DRAFT  
APPENDIX II \*

REPORTS ON TESTS OF STEEL-CONCRETE SANDWICH STRUCTURES

\* Not included in this translation

# CHAPTER I GENERAL

## 1.1 Scope

This code provides general requirements for design of steel-concrete sandwich structures. Other requirements which are not provided in this code shall conform with the Standard Specification for Design and Construction of Concrete Structures (1991) and the Design Code for Steel Structures (1987)

### [Commentary]

In this code a steel-concrete sandwich structure is a composite structure in which double steel skin plates and core concrete sandwiched by the double skin steel plates behave monolithically (see Fig. C1.1.1). Although open-sandwich structure in which a steel skin plate is attached to one side of the core concrete is also considered a kind of sandwich structures, it is not covered in this code. Generally a steel structure composed of steel plates can by itself sustain loads during construction before it is compounded with core concrete (see Fig C1.1.2). In this code general requirements are provided assuming that a sandwich structure is applied to a submerged box structure as shown in Fig.C1.1.3. Sandwich structures can be applied to other types of structures after a thorough examination is made based on the requirements specified in this code.

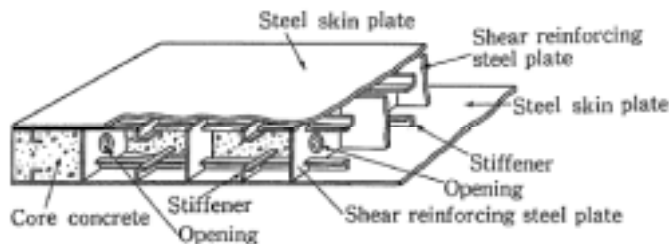

Fig. C1.1.1 Steel-concrete sandwich structure

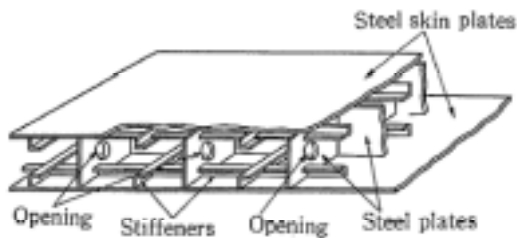

Fig. C1.1.2 Steel structure

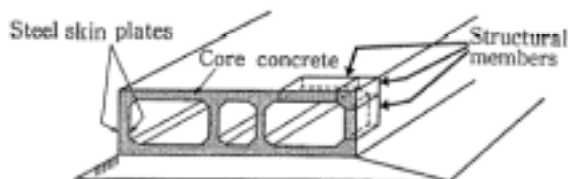

Fig. C1.1.3 Steel-concrete sandwich structure applied to submerged tunnel

## **CHAPTER 2 GENERAL REQUIREMENTS**

### **2.1 Design objectives**

This section shall conform with See.2.1 of Part 1 [Design] in the Standard Specification for Design and Construction of Concrete Structures.

### **2.2 Design lifetime**

This section shall conform with See.2.2 of Part 1 [Design] in the Standard Specification for Design and Construction of Concrete Structures.

### **2.3 Prerequisite of design**

Prerequisite of design based on this code is that construction is adequately carried out at site.

#### **[Commentary]**

Because it is a prerequisite that the entire space enclosed by steel plates is filled by concrete, close attention should be paid to concreting.

### **2.4 Design principles**

- (1) Limit states shown in Chap. 6 shall be examined.
- (2) Examination of limit states shall be made using the characteristic values of material strengths and loads and safety factors specified in See. 2.6.
- (3) Design shall be conducted considering that adequate construction can be achieved.

#### **[Commentary]**

- (1) A steel structure to be compounded with core concrete must be a structure which can by itself sustain loads during construction such as pressure of cast concrete. Limit states for steel structure, therefore, should be examined.
- (3) Proper structural details are necessary to ensure that the space enclosed by steel plates is filled by concrete.

### **2.5 Calculation of sectional forces and capacities**

This section shall conform with Sec.2.5 of Part 1 [Design] in the Standard Specification for Design and Construction of Concrete Structures.



## 2.6 Safety factors

Values for safety factors shall be chosen adequately according to the limit states considered. In general the values shown in **Table 2.6.1** may be used.

**Table 2.6.1 Standard values of safety factors**

	Material factors		Member factors		Structural analysis factors	Load factors	Structure factors
	Concrete	Steel	Flexure	Shear			
<b>During construction</b>							
ULS <sup>1)</sup> for S.S. <sup>2)</sup>	—	1.05	1.1	1.1	1.0	1.0	1.0
SLS <sup>1)</sup> for S.S.	—	1.0	1.0	1.0	1.0	1.0	1.0
ULS for C.S. <sup>2)</sup>	1.3	1.05	1.15	1.15~1.3 <sup>3)</sup>	1.0	1.0~1.2 <sup>4)</sup>	1.0
SLS for C.S.	1.0	1.0	1.0	1.0	1.0	1.0	1.0
<b>During service</b>							
ULS	1.3	1.05	1.15	1.15~1.3 <sup>3)</sup>	1.0	1.0~1.2 <sup>4)</sup>	1.1
SLS	1.0	1.0	1.0	1.0	1.0	1.0	1.0

1) ULS: ultimate limit state, SLS: serviceability limit state

2) S.S.: steel structure (before composite action starts)

C.S.: composite structure

3) Values shall be multiplied by 1.2 when effect of earthquake is considered.

4) Values shall be 1.0-1.2 for permanent loads, 1.1-1.2 for primary variable loads and 1.0 for secondary variable loads and accidental loads

## 2.7 Documentation of design calculation

This section shall conform with Sec. 2.8 of Part 1 [Design] in the Standard Specification for Design and Construction of Concrete Structures.

# CHAPTER 3 DESIGN VALUES FOR MATERIALS

## 3.1 General

This section shall conform with Sec.3.1 of Part 1 [Design] in the Standard Specification for Design and Construction of Concrete Structures.

## 3.2 Concrete

This section shall conform with Sec.3.2 of Part 1 [Design] in the Standard Specification for Design and Construction of Concrete Structures.

## 3.3 Steel

This section shall conform with Secs.2.1 and 5.2 of the Design Code for Steel Structures, where the specified material strengths, divided by the material factors may be taken as design values for materials.

## **CHAPTER 4 LOADS**

### **4.1 General**

This section shall conform with Sec.4.1 of Part 1 [Design] in the Standard Specification for Design and Construction of Concrete Structures.

### **4.2 Characteristic values for loads**

This section shall conform with Sec.4.2 of Part 1 [Design] in the Standard Specification for Design and Construction of Concrete Structures.

### **4.3 Kinds of loads**

#### **4.3.1 Loads during construction**

Loads on steel structure during construction such as pressure of cast concrete, hydrostatic pressure and soil pressure shall be determined adequately considering actual situation.

#### **[Commentary]**

Loads on steel structure before being compounded with core concrete may be the most severe for the steel structure.

#### **4.3.2 Loads during service**

This section shall conform with Sec.4.4 of Part 1 [Design] in the Standard Specification for Design and Construction of Concrete Structures.

## **CHAPTER 5 STRUCTURAL ANALYSIS**

### **5.1 General**

This section shall conform with Sec.5.1 of Part 1 [Design] in the Standard Specification for Design and Construction of Concrete Structures.

### **5.2 Calculation of sectional forces**

This section shall conform with Secs.5.2 and 5.3 of Part 1 [Design] in the Standard Specification for Design and Construction of Concrete Structures.

## **CHAPTER 6 LIMIT STATES**

### **6.1 Ultimate limit states during construction**

- (1) Ultimate limit states during construction shall be examined for axial force, flexural moment, shear and torsion caused by loads during construction.
- (2) Examination of ultimate limit states for steel structure which has not been compounded with core concrete (before composite action takes place) shall be conducted to conform with Sees. 7.2, 7.3 and 7.4 of the Design Code for Steel Structures, where the specified safety factors may be considered to be equal to products of the member factors, structural analysis factors, load factors and structure factors.
- (3) Examination of ultimate limit states after steel structure is compounded with core concrete (after composite action takes place) shall be conducted according to **Sec.6.3**.

#### **[Commentary]**

In cases such as submerged box structure, examination of ultimate limit states should be conducted not only for each member of a frame structure bounded by two planes normal to the box longitudinal axis, but also for the whole box structure based on three dimensional analysis.

When it is clarified even without calculation that torsional moments caused by loads during construction are less than torsional capacities of structure as expected in a submerged box structure, examination for torsion may not be necessary.

### **6.2 Serviceability limit states during construction**

- (1) Examination of limit states for deflection and deformation of steel structure not yet compounded with core concrete shall be conducted in conforming with Sec.7.5 of the Design Code for Steel Structures.
- (2) Examination of limit states for deflection and deformation after steel structure is compounded with core concrete shall be conducted according to Sec.6.4.

### **6.3 Ultimate limit states during service**

#### **6.3.1 General**

Examination of ultimate limit states during service shall be conducted for axial force, flexural moment, shear and torsion induced by loads during service.

#### **6.3.2 Flexural moment and axial force**

- (1) Examination of ultimate limit states for flexural moment and axial force shall be conducted according to Sec.6.2 of Part 1 [Design] in the Standard Specification for Design and Construction of Concrete Structures.

(2) For calculation of a design value of a sectional capacity the stress-strain curve as tension reinforcing steel plate may be obtained by **Eq.(6.3.1)** (see **Fig.6.3.1**).

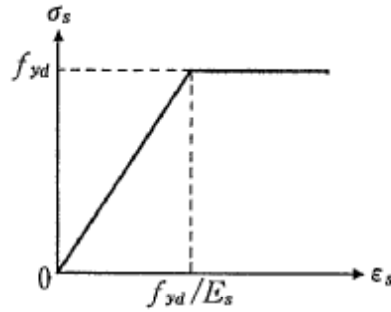

**Fig. 6.3.1 Stress-strain curve of tension reinforcing steel plate**

$$\sigma_s = E_s \varepsilon_s \quad \text{but not greater than } f_{yd}$$

where  $\sigma_s$  : tensile stress in tension reinforcing steel plate

$E_s$  : Young's modulus of tension reinforcing steel plate

$\varepsilon_s$  : tensile strain in tension reinforcing steel plate

$f_{yd}$  : design value for tension yield strength of tension reinforcing steel plate

The stress-strain curve as compression reinforcing steel plate may be obtained by **Eq. (6.3.2)** where buckling of compression reinforcing steel plate is considered (see **Fig. 6.3.2**).

$$\sigma'_s = E_s \varepsilon'_s \quad \text{but not greater than } f'_{ud} \tag{6.3.2}$$

where  $f'_{ud} = (t_f / b) \sqrt{E_s f'_{yd}}$  (6.3.3)

: design value for compression strength of compression reinforcing steel plate after buckling

$\sigma'_s$  : compressive stress in compression reinforcing steel plate

$E_s$  : Young's modulus of compression reinforcing steel plate

$\varepsilon'_s$  : compressive strain in compression reinforcing steel plate

$t_f$  : thickness of compression reinforcing steel plate

$b$  : spacing of stiffeners placed in the direction of member axis for compression reinforcing steel plate (see Fig. 6.3.3)

$f'_{yd}$  : design value for compression yield strength of compression reinforcing steel plate

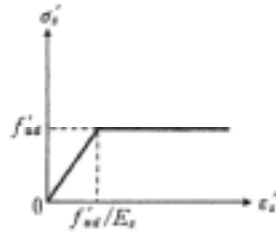

**Fig. 6.3.2 Stress-strain curve of compression reinforcing steel plate**

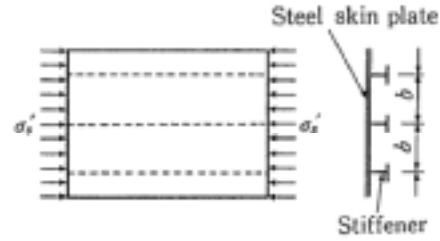

**Fig. 6.3.3 Spacing of stiffener for compression steel plate**

(3) Stiffener placed in the direction of member axis for tension reinforcing steel plate may be considered as tension reinforcing steel plate. The stress strain curve in this case may be obtained by **Eq. (6.3.4)**.

$$\sigma_s = E_s \varepsilon_s \quad \text{but not greater than } f_{yd} \quad (6.3.4)$$

where  $\sigma_s$  : tensile stress in stiffener

$E_s$  : Young' s modulus of stiffener

$\varepsilon_s$  : tensile strain in stiffener

$f_{yd}$  : design value of tension yield strength of stiffener

Stiffener placed in the direction of member axis for compression reinforcing steel plate may be considered as compression reinforcing steel plate. Since it may be considered that the buckling of stiffener does not take place, the stress-strain curve may be assumed by Eq.(6.3.5).

$$\sigma'_s = E_s \varepsilon'_s \quad \text{but not greater than } f'_{yd} \quad (6.3.5)$$

where  $\sigma'_s$  : compressive stress in stiffener

$E_s$  : Young' s modulus of stiffener

$\varepsilon'_s$  : compressive strain in stiffener

$f'_{yd}$  : design value of compression yield strength of stiffener

(4) Shear reinforcing steel plate placed in the direction of member axis may be considered as tension and compression reinforcing steel plate. The stress-strain curve in this case may be obtained by **Eqs.(6.3.6) and (6.3.7)**.

$$\sigma_s = E_w \varepsilon_s \quad \text{but not greater than } f_{eyd} \quad (6.3.6)$$

$$\sigma'_s = E_w \varepsilon'_s \quad \text{but not greater than } f'_{eyd} \quad (6.3.7)$$

$$\text{where } f_{eyd} = f_{wyd}(1 - \sigma_w/f_{wyd}) \quad (6.3.8)$$

: design value for compression yield strength of shear reinforcing steel plate used as compression reinforcing steel plate

$$f'_{eyd} = f'_{wyd}(1 - \sigma_w / f_{wyd}) \quad (6.3.9)$$

$f'_{eyd}$  : design value for tension yield strength of shear reinforcing steel plate used as tension reinforcing steel plate

$$\sigma_w = f_{wyd}(v_d - v_{od}) / (v_{u2d} - v_{od}) \text{ but not less than } 0$$

$\sigma_w$  : tensile stress in shear reinforcing steel plate as shear reinforcing steel plate

$\sigma_s$  : tensile stress in shear reinforcing steel plate as tension reinforcing steel plate

$E_w$  : Young's modulus of shear reinforcing steel plate

$\varepsilon_s$  : tensile strain in shear reinforcing steel plate as tension reinforcing steel plate

$\sigma'_s$  : compressive stress in shear reinforcing steel plate as compression reinforcing steel plate

$\varepsilon'_s$  : compressive strain in shear reinforcing steel plate as compression reinforcing steel plate

$f_{wyd}$  : design value for tension yield strength of shear reinforcing steel plate, not greater than 392.3MPa

$f'_{wyd}$  : design value for compression yield strength of shear reinforcing steel plate, not greater than 392.3MPa

$v_d$  : design value for shear force

$v_{od}$  : design value for shear capacity carried by other than so-called truss mechanism at ultimate in Eq.(6.3.12)

$v_{u2d}$  : design value for shear capacity calculated by Eq.(6.3.12)

### [Commentary]

(2) A stiffened steel plate maintains its strength even after buckling and can be expected to contribute to the ultimate limit state for flexural moment and axial force. According to a previous study, Eq.(6.3.3) predicts conservatively the design value for compressive strength of steel plate between stiffeners, if the stiffeners, which are embedded sufficiently into concrete in order not to be pulled out, provide proper confinement.

(4) A shear reinforcing steel plate placed in the direction of member axis can be considered as a tension and compression reinforcing steel plate as well. The yield strength, however, needs to be reduced by considering the effects of stresses as shear reinforcing Steel plate. Although the reduced yield strength cannot be predicted accurately at present due to inadequate previous studies, it can be predicted conservatively by Eqs.(6.3.8) and (6.3.9).

### 6.3.3 Shear

(1) Examination of ultimate limit states for shear shall be conducted according to See.6.3 of Part 1 [Design] in the Standard Specification for Design and Construction of Concrete Structures.

(2) Design values for shear capacities as a linear member may be obtained according to (3) through (7).

(3) In the case of no shear reinforcing steel plate being provided, the shear capacity is obtained by **Eq.(6.3.10)**.

$$V_{u0d} = f_{vcd} b_w d / \gamma_{bl} \quad (6.3.10)$$

where  $f_{vcd}$  : design value for shear strength in the case of no shear reinforcing steel plate being provided, a greater of  $0.1914f_{cd}^{1/3} \beta_d \beta_p \beta_n k$  and  $0.1879f_{cd}^{1/2} \beta_d \beta_p \beta_a$

$$\beta_d = (1000/d)^{1/4} \text{ but not greater than } 1.5(d:\text{mm})$$

$$\beta_p = (100p_w)^{1/3} \text{ but not greater than } 1.5$$

$$\beta_n = 1 + M_o/M_d \text{ but not greater than } 2.0 \text{ (in case of } N'_d \geq 20)$$

$$= 1 + 2M_o/M_d \text{ but not less than } 0 \text{ (in case of } N'_d < 0)$$

$$\beta_a = 5/(1+(a/z)^2)$$

$$p_w = A_s/(b_w d)$$

$b_w$  : web width of member

$d$  : effective depth

$\gamma_{bl}$  : member factor which may be assumed to be 1.3 generally

$k$  : reduction factor for shear cracking strength of a steel-concrete sandwich linear member to that of an ordinary reinforced concrete linear member

$f'_{cd}$  : design value for compressive strength of core concrete, in MPa

$M_d$  : design value for flexural moment

$M_o$  : flexural moment to cancel stress induced by axial force at tension end for flexural moment,  $M_d$

$N'_d$  : design value for axial force

$a$  : distance from front face of support to loading point

$z$  : distance from acting point of resultant of compressive stresses to centroid of tension reinforcing steel plate

$A_s$  : cross-sectional area of tension reinforcing steel plate

(4) In the case of shear reinforcing steel plate being placed in the direction of member axis (see **Fig. 6.3.4**), the shear capacity may be obtained by taking a lesser of  $V_{uld}$  by **Eq.(6.3.11)** and  $V_{u2d}$  by **Eq.(6.3.12)**.

$$V_{uld} = k_m(V_{ulod} - V_{u0d}) + V_{u0d} \quad (6.3.11)$$

$$V_{u2d} = \sin^2 \alpha (\cot \theta + \cot \alpha) t_w z f_{wyd} / \gamma_{b2} + V_{od} \quad (6.3.12)$$

$$\text{where } V_{ulod} = f_{vud} b_w d / \gamma_{bl} \quad (6.3.13)$$

$k_m$  : coefficient for consideration of influence of spacing normal to member axis of shear reinforcing steel plates on shear capacity =  $1/(b_w/d)^{1/2}$  but not greater than 1.0

$f_{vud}$  : design value for shear strength when compression diagonal strut in core concrete fails, a greater of  $1.253f_{cd}^{1/2}$  and  $0.1879f_{cd}^{1/2} \beta_d \beta_p \beta_s$

$$\beta_s = 5/(1 + \cot^2 \theta)$$

$b_w$  : web width of member which is assumed to be spacing normal to member axis of shear reinforcing steel plates

$\alpha$  : angle to member axis of tension diagonal strut (or principal tensile force) in shear reinforcing steel plate, which may be assumed to be  $60^\circ$

$\theta$  : angle to member axis of diagonal compression strut in core concrete, which may be assumed to be  $30^\circ$  but not less than  $\cot^{-1}(a/z)$

$t_w$  : thickness of shear reinforcing steel plate

$f_{wyd}$  :design value for tension yield strength of shear reinforcing steel plate, not greater than 392.3MPa

$\gamma_{b2}$  :member factor, which may be assumed to be 1.15 generally

$V_{od}$  :design value for shear capacity carried by other than truss mechanism at ultimate

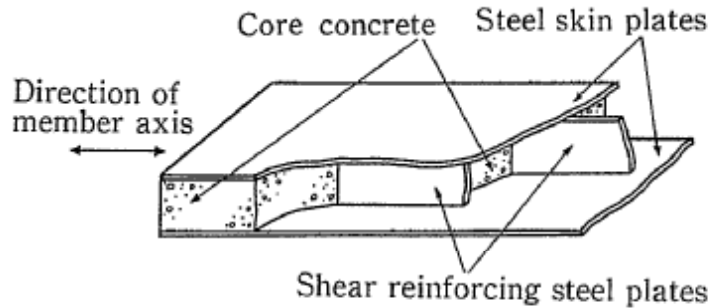

**Fig. 6.3.4 Shear reinforcing steel plate placed in the direction of member axis**

(5) In the case of shear reinforcing Steel plate being placed in the direction normal to member axis (see Fig. 6.3.5), the shear capacity may be obtained by taking a lesser of  $V_{uld}$  by Eq.(6.3.14) and  $V_{u2d}$  by Eq.(6.3.15).

$$V_{uld} = f_{vud}b_wd/\gamma_{bl} \quad (6.3.14)$$

$$V_{u2d} = \sin\alpha(\cot\theta + \cot\alpha)A_wf_{wyd} (Z/S)/Y_{b2}+V_{od} \quad (6.3.15)$$

where  $f_{vud}$  : design value for shear strength when compression diagonal strut in core concrete fails, a greater of  $0.1914f_{cd}^{1/3} \beta_d \beta_p \beta_n k$  and  $0.1879f_{cd}^{1/2} \beta_d \beta_p \beta_s$

$b_w$  : web width of member

$\alpha$  :angle to member axis of shear reinforcing steel plate

$\theta$  :angle to member axis of compression diagonal strut,  $\cot^{-1}((s - z \cdot \cot\alpha)/z)$

$A_w$  :cross-sectional area of shear reinforcing steel plate, tubu

$S$  : spacing parallel to member axis of shear reinforcing steel plates



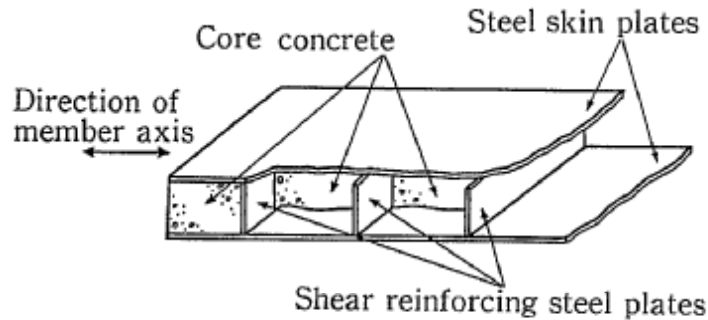
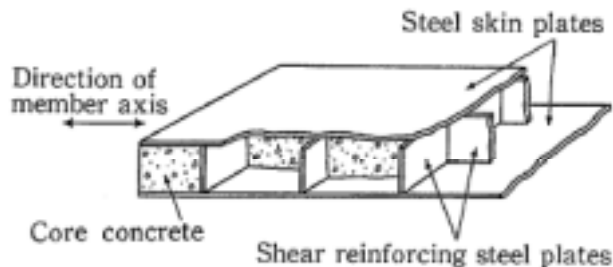

Fig. 6.3.5 Shear reinforcing steel plate placed in the direction normal to member axis

(6) In the case of shear reinforcing steel plates being placed in the direction both parallel and normal to member axis (see **Fig. 6.3.6**), it may be assumed that the shear capacity is a greater of a design value for shear capacity calculated by assuming that there is only shear reinforcing steel plate placed in the direction of member axis and another by assuming that there is only shear reinforcing steel plate placed in the direction normal to member axis. If spacing of shear reinforcing steel plate placed in the direction normal to member axis is small and  $s \cdot z \cdot \cot \alpha < z \cdot \cot 30^\circ$ , the shear capacity shall be calculated by assuming that angle to member axis of compression diagonal strut in core concrete,  $\theta$  is equal to  $\cot^{-1}((s - z \cdot \cot \alpha) / z)$



**Fig. 6.3.6 Shear reinforcing steel plate placed in the direction both parallel and normal to member axis**

(7) Even in the case of shear reinforcing steel plate being provided, if the design value for shear capacity calculated by **Eq.(6.3.10)** in which no shear reinforcing steel plate is provided is greater than the values calculated according to (4) through (6) in which shear reinforcing steel plate is provided, the design value for shear capacity may be obtained by **Eq.(6.3.10)**.

[Commentary]

(3)(4)(5) **Equations (6.3.11)-(6.3.15)** provide capacities of the so-called truss mechanism. **Equations (6.3.11)** and **(6.3.14)** calculate the capacities when compression diagonal strut in truss mechanism fails while **Eqs.(6.3.12)** and **(6.3.15)** when yielding of shear reinforcing steel plate.

Shear capacity,  $V_{od}$  carried by other than truss mechanism is generally snail at ultimate, so it is preferable to neglect it for conservativeness. Previous test results, however, indicate that Eqs.(6.3.11)-(6.3.15) underestimate too conservatively the shear capacity when shear reinforcement is placed in the direction of member axis, when ratio of shear span to effective depth,  $a/d$  is small, or when tension reinforcing steel plate is thick. In such cases shear capacity carried by other than truss mechanism can be considered provided that its value is confirmed by experiment or other means.

The larger the spacing of shear reinforcing steel plate is, the lesser the capacity of compression diagonal strut in core concrete. Despite the lack of experimental data, previous test results show that Eq. (6.3.11) gives conservative prediction of the shear capacity.

For the calculation of  $z$  in Eqs.(6.3.10)-(6.3.15), the location of resultant of compressive stresses can be obtained by using flexural stresses calculated in **Sec. 6.3.2**.

The coefficient,  $k$ , in **Eqs.(6.3.10)** and **(6.3.14)** is to express the reduction in capacity of compression diagonal strut in core concrete forming truss mechanism, which is preceded by the reduction in shear cracking strength due to existence of shear connector. Compared with ordinary reinforced concrete a 15% reduction was observed in a previous test.

To examine the ultimate limit states during earthquake, member factors in **Eqs.(6.3.10)-(6.3.15)** will be multiplied by 1.2 in order to increase safety against shear.

(6) There have been few studies on shear capacity in the Case of shear reinforcing Steel plates placed' in the direction both parallel and normal to member axis. Further studies in this area should be carried out. A method to predict conservatively the shear capacity is provided here.

(7) In the case of a small ratio of distance between front face of support and loading point to effective depth (ratio of shear span to effective depth,  $a/d$ ), the shear capacities, obtained by **Eqs.(6.3.11)-(6.3.15)**, for members with shear reinforcing steel plate could be smaller than the shear capacity, obtained by **Eq.(6.3.10)**, for members without shear reinforcing steel plate. In this case contribution of shear reinforcing steel plate is so snail that it is assumed that no shear reinforcing steel plate is provided. The shear capacity of compression diagonal strut in core concrete obtained by **Eq.(6.3.10)** can be considered as the shear capacity.

### **6.3.4 Torsion**

Examination of ultimate limit state for torsion shall be conducted in an adequate way.

#### **[Commentary]**

Studies on torsion of steel-concrete sandwich structure are necessary, since there has not been any in the past. It can be considered that torsional capacity of steel-concrete sandwich member is greater than that of the steel structure obtained by Sec. 7.2.4 of the Design Code for Steel Structures and that of the core concrete obtained by Sec. 6.4.2 of the Standard Specification for Design and Construction of Concrete Structures.

When it is clarified without design calculation that torsional moment during service is less than torsional capacity of steel-concrete sandwich member during service as seen in submerged box structures, examination of ultimate limit state for torsion can be omitted.

## **6.4 Serviceability limit states during service**

### **6.4.1 Deflection and deformation**

(1) Examination for deflection and deformation shall be conducted according to See.7.4 of the Standard Specification for Design and Construction of Concrete Structures.

(2) For calculation of cracking moment the effect of shear connector on cracking shall be considered.

#### **[Commentary]**

(1) For structures such as submerged box structures, it is significant to examine deflection and deformation along the longitudinal axis.

(2) A simple method to consider the effect of shear connector is to reduce appropriately a design value for flexural strength of concrete provided by **Eq.(3.2.1)** in the Standard Specification for Design and Construction of Concrete Structures. In a previous test cracking strength was reduced to less than 50% of the flexural strength.

## **CHAPTER 7 STRUCTURAL DETAILS**

### **7.1 Steel plate**

Anti-corrosion treatment shall be provided to steel plate.

#### **[Commentary]**

Anti-corrosion treatment is necessary for steel plate except for the parts directly in contact with concrete. Anti-corrosion treatment is especially important for parts exposed to external environment.

### **7.2 Shear reinforcing steel plate**

Both ends of shear reinforcing steel plate shall be anchored fully to tension and compression reinforcing steel plates.

### **7.3 Corner connection**

(1) Tension and compression reinforcing steel plate and shear reinforcing steel plate placed in the direction of member axis in a member connected at a corner connection shall be extended and connected in the corner connection, so that their full strengths are transferred to respective steel plates member (see **Fig. 7.3.1**).

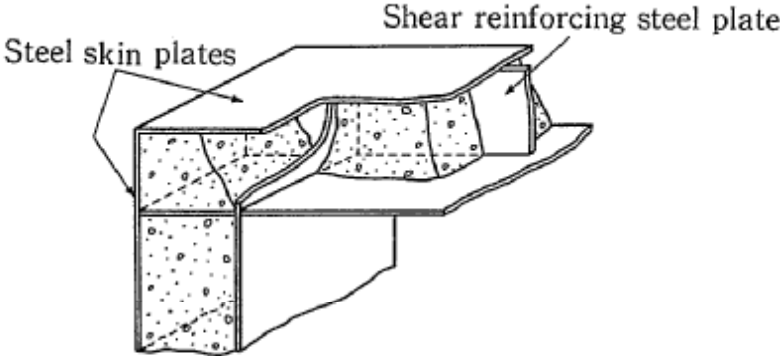

**Fig. 7.3.1 Corner connection**

(2) When a haunch is provided in a corner connection, structural details shall be given to prevent a steel skin plate at the side of haunch from delaminating. In general structural details as in Fig.7.3.2 shall be provided.

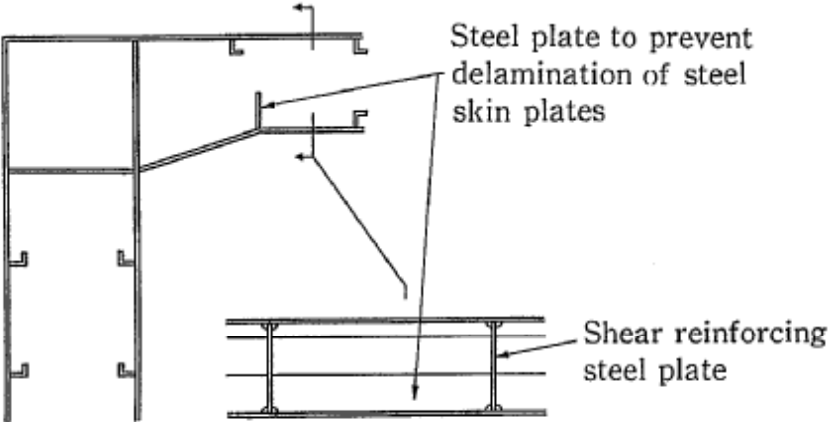

**Fig. 7.3.2 Steel structure around haunch**

[Commentary]

(1) From a previous study it is found that a corner connection can develop its full capacity for a flexural moment to open the corner by providing the inner steel skin plates (tension reinforcing steel plate) extended into the corner connection and connected fully with the outer steel skin plates (compression reinforcing steel plate). For a flexural moment closing the corner the corner connection can develop its full capacity by providing the outer steel skin plate (tension reinforcing steel plate) extended into the corner connection and connected fully with the other outer steel skin plate at outer corner of the corner connection. For shear, full capacity of connected members can be transferred by extending fully the shear reinforcing steel plates of the connected members into the corner connection. In this case an equivalent of the largest amount of shear reinforcing steel plate among the connected members will be placed in the corner connection. Therefore, it is preferable to place the shear reinforcing steel plates at the same location in the connected members. In usual cases core concrete in a corner connection develops its capacity large enough to transfer moments, axial forces and shear forces to connected members. For the cases with large amount of reinforcing steel plate, however, failure of compressive diagonal strut in core concrete in the corner connection could determine the capacity of corner connection.

(2) Since a steel skin plate at haunch side is bent, direction of axial force in the skin plate is changed. In order to resist a component of the axial force created by the bent skin plate, steel plates will be placed in the direction normal to member axis as shown in **Fig. 7.3.2** indicating the case where shear reinforcing steel plates are placed in the direction of member axis. In the case where shear reinforcing steel plates are not placed in the direction of member axis, the steel plates placed in the direction normal to member axis will be extended to the steel skin plates at the other side of the haunch.

## 7.4 Shear connector

(1) Shear connectors shall be located at appropriate intervals for full composite action. Arrangement of shear connector may be determined by confirming **Eq.(7.4.1)**

$$\gamma_i H_d \left/ \sum_{i=1}^{N_{sc}} V_{scdi} \right. \leq 1.0 \quad (7.4.1)$$

where  $H_d$  : design value for shear force per unit width transferred between skin plate and core concrete at portion L

$$= t_f \sigma_s \quad (7.4.2)$$

$\gamma_i$  : structure factor

$V_{scdi}$  : design value for shear transfer capacity of individual shear connector per unit width

$N_{sc}$  : total number of shear connectors per unit width at portion L

L : portion between maximum flexural moment and zero flexural moment sections

$t_f$  : thickness of steel skin plate at maximum flexural moment

$\sigma_s$  : tensile stress in steel skin plate at maximum flexural moment section ( $=f_{yd} (M_d/M_{ud})$ )

$M_d$  : design value for flexural moment at maximum flexural moment section

$M_{ud}$  : design value for flexural capacity of maximum flexural moment section

(2) Design value for shear transfer capacity of shape steel as shear connector may be obtained by **Eq.(7.4.3)** (see **Fig. 7.4.1**).

$$V_{scd} = 5.590 h_{sc} w_{sc} f_{cd}'^{1/2} k_1 k_2 k_3 / \gamma_{b1} \quad (7.4.3)$$

but not greater than  $t_{sco} w_{sc} (f_{scyd} / \sqrt{3}) / \gamma_{b2}$

where  $k_1 = 2.2(t_{sc}/h_{sc})^{2/3}$  but not greater than 1.0

$k_2 = 0.4(t_f/t_{sc})^{1/2} + 0.43$  but not greater than 1.0

$k_3 = (s_{sc}/h_{sc}/10)^{1/2}$  but not greater than 1.0

$f_{cd}'$  : design value for compressive concrete strength, in MPa

$h_{sc}$  : height of shear connector

$w_{sc}$  : width in the direction normal to shear force of shear connector

$t_{sco}$  : a lesser of thickness of shear connector considering welded part and thickness of shear connector itself

$f_{scyd}$  : design value for tension yield strength of shear connector

$t_f$  : thickness of steel plate to which shear connector is attached

$t_{sc}$  : thickness of shear connector

$s_{sc}$  : spacing in the direction of shear force of shear connectors

$\gamma_{b1}$  : member factor which may be 1.3 generally

$\gamma_{b2}$  : member factor which may be 1.15 generally

$\gamma_c$  : material factor for calculation of  $f_{cd}'$  Which may be 1.3 generally

$\gamma_s$  : material factor for calculation of  $f_{scyd}$  Which may be 1.05 generally

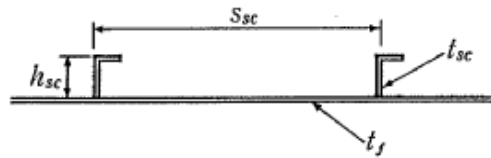

**Fig. 7.4.1 Shear connector of shape steel**

(3) Design value for shear transfer capacity of stud as stud as connector may be obtained by **Eq.(7.4.4).**

$$\begin{aligned} V_{scd} &= 9.395 d_{sc}^2 f_{cd}'^{1/2} \quad (\text{for } h_{sc}/d_{sc} \geq 5.5) \\ &= 1.722 d_{sc} h_{sc} f_{cd}'^{1/2} \quad (\text{for } h_{sc}/d_{sc} < 5.5) \end{aligned} \quad (7.4.4)$$

where  $d_{sc}$  : diameter of stud

(4) Stiffener placed in the direction normal to member axis and shear reinforcing steel plate placed in the direction normal to member axis may be used as shear connector. Design value for reinforcing steel plate as shear connector shear transfer capacity of shear may be obtained by **Eq.(7.4.5).**

$$V_{scd} = t_{sco} W_{sc} f_{esd} / \gamma_{b2} \quad (7.4.5)$$

$$\text{where } f_{esd} = (f_{wyd} / \sqrt{3}) (1 - \sigma_w / f_{wyd}) \quad (7.4.6)$$

$\sigma_w = f_{wyd}(V_d - V_{od}) / (V_{u2d} - V_{od})$  but no less than  
 : tensile stress in shear reinforcing steel plate as shear reinforcing steel plate  
 $f_{wyd}$  : design value for tension yield strength of shear reinforcing steel plate, not greater than 392.3Mpa  
 $V_d$  : design value for shear force  
 $V_{od}$  : design value for shear capacity carried by other than truss mechanism at ultimate given in **Eq.(6.3.15)**  
 $V_{u2d}$  : design value for shear capacity calculated by **Eq.(6.3.15)**

(5) When restriction of slip between Steel skin plate and core concrete is expected at member end or other places, any shear connector needs not be arranged.

### [Commentary]

(1) Number of shear connectors to be arranged can be obtained by dividing shear force acting on shear connector by shear transfer capacity of individual shear connector.

Shear force acting on shear connector is a change in axial force induced by loading in steel plate to which shear connector is attached. It is necessary that shear connector be designed for maximum shear force among those induced by the combined expected loads. Normally shear force may be predicted by the following way. At a section of maximum flexural moment a steel skin plate is subject to maximum axial force and at a section of zero flexural moment tensile force in steel skin plate is zero. Change in axial force at portion, L between the sections of maximum and zero flexural moments is equal to the axial force in steel skin plate at the section of maximum flexural moment. Therefore, the design value,  $H_d$  for shear force per unit width acting at portion, L can be expressed by **Eq.(7.4.2)**. This shear force,  $H_d$  and the summation of shear transfer capacities of shear connectors arranged at portion, L will be confirmed to verify **Eq.(1.4.1)**. Spacing of shear connectors will be equal to or less than half the distance between sections of maximum and zero flexural moments.

**Equation (7.4.1)** is for examination of shear connectors arranged in tension zone. However, no examination is necessary for shear connectors in compression zone being arranged symmetrically to those in the tension zone.

(2)(3) Shear transfer capacity of shear connector depends on shape of shear connector, thickness of steel plate where shear connector is attached, restriction of out-plane deflection of steel plate, spacing of shear connectors, concrete strength, and steel strengths of shear connector and skin plate, and needs to be determined by appropriate experiments, etc.

For shape steel used as shear connector, design value for shear transfer capacity can be predicted conservatively by using Eq.(7.4.3) which was derived from previous studies on shear transfer capacity of shape steel as shear connector.

When shape steel is used as shear connector, shear connector with head, such as L-shape and T-shape steel, will be used either in the direction of member axis or in the direction normal to member axis or in both directions in order to achieve better composite effect.

From previous studies it is found that Eq.(7.4.4) derived for stud as shear connector may predict

capacity too conservatively in some cases. The capacity can be obtained by other means if its accuracy can be confirmed by experiment, etc.

(4) When shear reinforcing steel plate placed in the direction normal to member axis is used as shear connector, direct shear capacity of its connection with base steel plate which is expressed by Eq.(7.4.5) can be considered as shear transfer capacity. Direct shear capacity of shear reinforcing steel plate needs to be obtained, considering the effect of tensile stress induced as shear reinforcing steel plate on the direct shear capacity. Since there are only few studies on the effect, it is concluded that direct shear capacity would be obtained by Eq. (7.4.5) conservatively.

(5) Generally shear connectors cause cracking, hence reduce cracking capacities of a member. Therefore: it is possible to increase cracking capacity by arranging no shear connector at certain parts of a member where shear force acts if slip between steel plate and core concrete could be prevented by some means. In a previous test result ultimate shear capacity was increased to be larger than double due to an increase in shear cracking capacity.

## **7.5 Minimum thickness of steel plate**

Minimum thickness of tension, compression, shear reinforcing steel plate shall be determined appropriately to prevent change in shape during fabrication, transportation and construction and damage due to corrosion and erosion. In general minimum thickness of steel plate may be 8mm.

## **7.6 Minimum spacing of steel plates**

Minimum spacing of steel plates shall be determined, so that concrete will be cast fully in spaces enclosed by the steel plates.

### **[Commentary]**

For a steel plate to which shear connector or stiffener is attached, it is necessary to determine minimum spacing, considering clear spacing which is spacing subtracted by height of the shear connector or stiffener.

## **7.7 Opening of steel plate**

Size of an opening of tension, compression or shear reinforcing steel plate shall be minimized. Vicinity of the opening shall be reinforced properly in order to maintain the required strength of the steel plate.

### **[Commentary]**

For construction requirement such as concreting, opening of tension, compression and shear reinforcing steel plate is usually provided.