

III. GUIDELINES FOR RETROFIT OF CONCRETE STRUCTURES

- DRAFT -

GUIDELINES FOR RETROFIT OF CONCRETE STRUCTURES

- DRAFT -

(Translation from the CONCRETE LIBRARY No.95 published by JSCE, September 1999)

JSCE Working Group on Retrofit Design of Concrete Structures in Specification Revision Committee

Tamon UEDA, Chairman

Takumi SHIMOMURA, Secretary

Members

Susumu INOUE

Takafumi SUGIYAMA

Zhishen WU

Kazushi TAKIMOTO

Akira KOBAYASHI

Hiroshi NAKAI

Eiichi SAKATA

Hikaru NAKAMURA

Tsutomu SATO

Yuzuru HAMADA

Yasuhiko SATO

Masahiro HAYASHI

Masashi SANO

Mutsumi MIZUKOSHI

Former Members

Shigeki UNJO

Hiroyuki OHGA

Observer

Yasushi KAMIHIGASHI

Guidelines presented were originally published in Japanese in JSCE's Concrete Library No.95 in 1999 as the work of the Working Group on Retrofit Design of Concrete Structures under the Subcommittee on Revision of Standard Specification of JSCE's Concrete Committee. They are the first guidelines for retrofit of concrete structures issued by JSCE. The guidelines prepared with performance-based concept provide flow chart for retrofitting process, inspection and verification of performances of existing structures, selection of retrofitting methods, specification of retrofitting materials, verification of performances of retrofitted structures, and detailing and execution for retrofitting. Although only external cable method, bonding and jacketing method and overlaying and jacketing method are covered in the guidelines, the main concept is applicable to any retrofitting method. The original Japanese version of the guidelines is accompanied by manuals and design examples of each retrofitting method covered by the guidelines.

Keywords: retrofit of concrete structures, external cable method, steel plate bonding method, fiber-reinforced plastic bonding method, steel plate jacketing method, fiber-reinforced plastic jacketing construction method, surface overlaying method, Reinforced concrete jacketing method

Tamon UEDA is an Associate Professor in the Department of Civil Engineering at Hokkaido University. He obtained his Dr.Eng. from the University of Tokyo in 1982. His research interests widely cover mechanics of reinforced concrete structures, steel-concrete composite structures and continuous fiber reinforced concrete structures. He is a member of JSCE.

Takumi SHIMOMURA is an Associate Professor in the Department of Civil and Environmental Engineering at Nagaoka University of Technology. He obtained his Dr.Eng. from the University of Tokyo in 1993. His research interests include mathematical modeling of time-dependent problems in concrete materials and structures. He is a member of JSCE.

GUIDELINES FOR RETROFIT OF CONCRETE STRUCTURES

- DRAFT -

CONTENTS

CHAPTER 1 GENERAL PROVISIONS.....	203
1.1 Scope.....	203
1.2 Definitions.....	204
CHAPTER 2 FUNDAMENTALS OF RETROFIT.....	206
2.1 General.....	206
2.2 Flow of Retrofitting Process.....	207
2.3 Changes over Time in Performance of Retrofitted Structures.....	210
CHAPTER 3 MATERIALS.....	211
3.1 General.....	211
3.2 Materials in Existing Structures.....	211
3.3 Quality of Materials.....	212
3.3.1 External Cables.....	212
3.3.2 Steel Plates.....	214
3.3.3 Continuous Fiber Sheets.....	214
3.3.4 Adhesive.....	214
3.3.5 Fill Material.....	215
3.3.6 Cement-Based Reinforcing Material.....	215
3.3.7 Steel.....	217
3.4 Material Characteristic Values and Design Values.....	217
3.4.1 External Cables.....	217
3.4.2 Steel Plates.....	218
3.4.3 Continuous Fiber Sheets.....	218
3.4.4 Cement-Based Reinforcing Materials.....	220
3.4.5 Steel.....	221
CHAPTER 4 LOAD ACTION AND ENVIRONMENTAL ACTION.....	221
CHAPTER 5 INSPECTION OF EXISTING STRUCTURES.....	223
5.1 General.....	223
5.2 Inspection Method.....	223
CHAPTER 6 PERFORMANCE VERIFICATION FOR EXISTING STRUCTURES.....	226
CHAPTER 7 SELECTION OF RETROFITTING METHOD.....	228
CHAPTER 8 CONSIDERATIONS IN RETROFITTING DESIGN AND CONSTRUCTION.....	233
CHAPTER 9 PERFORMANCE VERIFICATION FOR RETROFITTED STRUCTURES.....	233
9.1 General.....	233
9.2 Verification of Safety.....	233
9.2.1 Flexural and Axial Load-Carrying Capacity.....	233
9.2.2 Shear Capacity of Bar Members.....	237
9.2.3 Punching Shear Capacity of Surface Members.....	240
9.2.4 Flexural Fatigue Capacity.....	240

9.2.5 Shear Fatigue Capacity of Bar Members.....	241
9.2.6 Punching Shear Fatigue Capacity of Surface Members	241
9.2.7 External Cable Fretting Fatigue Capacity.....	242
9.2.8 Ultimate Deformation.....	242
9.3 Verification of Serviceability.....	243
9.3.1 Stress Level.....	243
9.3.2 Crack Width.....	244
9.3.3 Displacement and Deformation.....	245
9.4 Verification of Restorability	246
9.4.1 Deformation	246
9.4.2 Stress Level.....	248
References.....	249

CHAPTER 1 GENERAL PROVISIONS

1.1 Scope

- (1) These (draft) guidelines for retrofit cover the fundamentals of the retrofitting of existing concrete structures.
- (2) These (draft) guidelines for retrofit cover the retrofitting of structures using the external cable method, the bonding and jacketing method, and the overlaying and jacketing methods, based on existing technologies.

[Commentary]

(1) The fundamentals of ordinary design and construction of concrete structures are covered in the Standard Specification for Design and Construction of Concrete Structures (Design)[1] and (Construction)[2], published by the Japan Society of Civil Engineers (hereafter "Standard Specification"), while matters pertaining to seismic design are covered in the Standard Specification (Seismic Design)[3]. Standards relating to the maintenance of concrete structures are covered in the Guidelines for Maintenance of Concrete Structures (Draft)[4] published by the Japan Society of Civil Engineers (hereafter "Maintenance Guidelines"). These (draft) guidelines are designed to complement these documents and indicate standards for the retrofitting of existing concrete structures, which in recent years has been applied in an increasingly number of cases. These guidelines concentrate on design and construction considerations for ensuring that the retrofitting members bond to the existing structure and methods for verifying the performance of retrofitted structures, matters that are unique to and critical for retrofitting. Matters that are common to the Standard Specification and Maintenance Guidelines have been omitted.

These (draft) guidelines are applicable when the mechanical characteristics of structures are changed to improve their performance, and when performing the "Retrofit" "Restoration of Functions" and "Improvement of Functions" processes described in the Maintenance Guidelines.

This publication is made up of the (draft) Guidelines for retrofit and supplementary materials. The (draft) guidelines cover the flow of the retrofitting process and general matters. The supplementary materials include manuals of retrofitting methods, sample designs and other reference materials. The manuals of retrofitting methods contain practical considerations relating to retrofitting design and construction based on existing technologies. The sample designs show actual application of the matters covered in the (draft) guidelines and manuals.

(2) Many different retrofitting methods are currently being implemented. In the (draft) Maintenance Guidelines, the retrofitting methods are classified as shown in **Figure C1.1.1**.

Structural retrofitting technologies are currently at the stage of general research, and the performance results and organization of technologies used for the different methods are not uniform. In the future, it is expected that new methods will be developed and new views will be proposed for existing methods as well. These (draft) guidelines cover the fundamental approach to retrofit as well as specific design and construction methods for those methods that are currently applied most often, based on existing technologies.

Of the many retrofitting methods, these (draft) guidelines provide detailed design and construction methods for the external cable construction method, the bonding and jacketing construction method and the overlaying and jacketing construction method.

The external cable construction method is included under (9) Prestressing introduction method in the retrofitting methods shown in **Figure C1.1.1**.

The bonding and jacketing construction method is classified as a method that involves increasing the number of retrofitting members and includes the (6) Steel plate bonding method (7) Fiber-reinforced plastic bonding method and (8) Steel plate jacketing construction method, as well as the fiber-reinforced plastic jacketing construction method (not shown in the figure). However, this includes only the fiber-reinforced plastic bonding and fiber-reinforced plastic jacketing construction methods that use continuous fiber sheets and does not cover cases in which continuous fiber reinforced plates fabricated at the factory are used.

The overlaying and jacketing construction method is a retrofitting method in which concrete sections are added and corresponds to (2) Overlaying construction method and (3) Jacketing construction method in the figure.

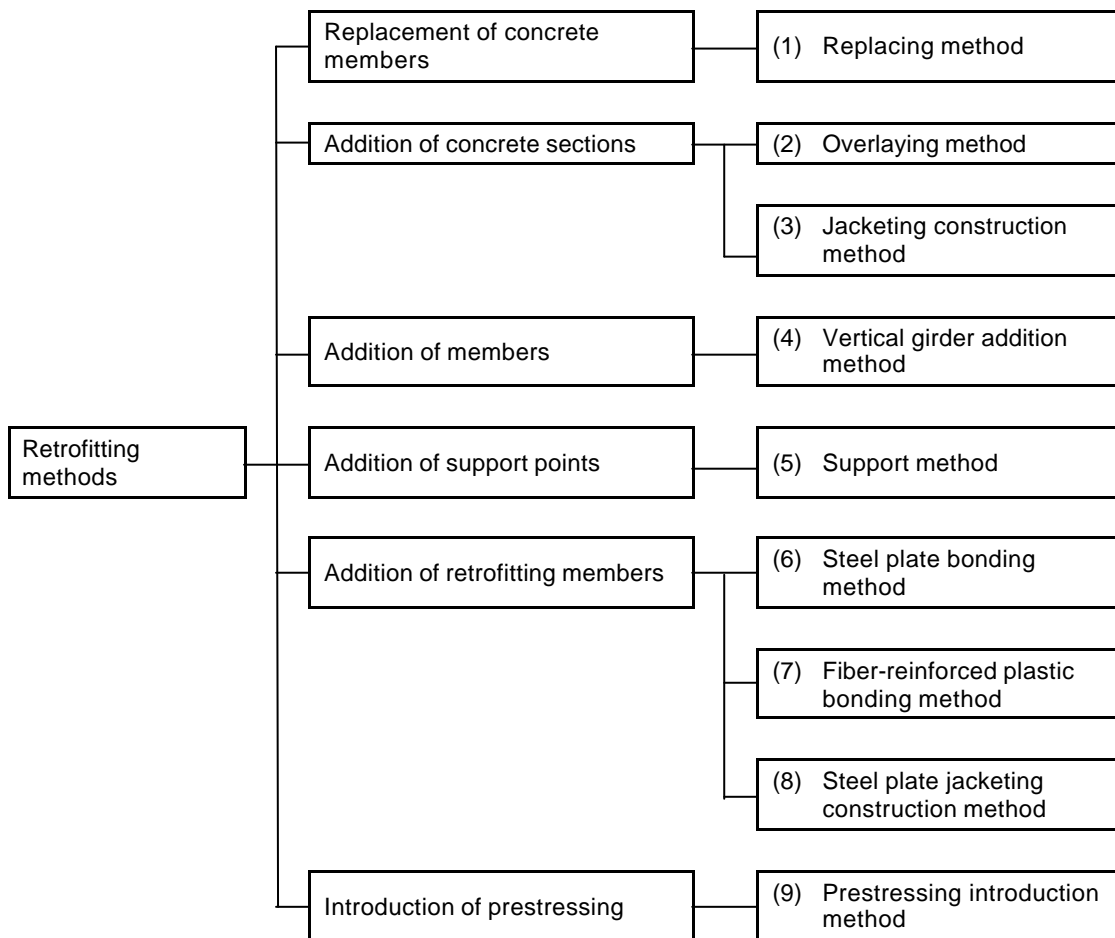

Figure C1.1.1 Sample retrofitting methods [5]

Of the retrofitting methods shown in **Figure C1.1.1**, the (1) Replacing method (4) Vertical girder addition method and (5) Support method are not specifically covered in these (draft) guidelines. In future revisions, methods other than those shown in these (draft) guidelines will be included, and those currently included will be revised to reflect technological progress.

The items in these (draft) guidelines alone may not be adequate for the design and construction of every structure. Moreover, design and construction of retrofitted structures with even more advanced construction methods is expected to become possible with technological progress. In such cases, it is not necessary to adhere to the methods shown in these (draft) guidelines. However, the fundamentals of and approach to retrofit will no doubt be the same, so the gist of these (draft) guidelines should be observed and they should be applied appropriately in accordance with the situation.

It should be noted that, in general, retrofitting technologies for structures are at the research stage, and many matters have not been finalized. Also, when conducting retrofitting in accordance with these (draft) guidelines, it is important to perform suitable maintenance after retrofitting.

1.2 Definitions

The following terms are defined for use in these (draft) guidelines:

Continuous fiber prestressing materials:

Of the continuous fiber retrofitting members, the general term for those that can be used as prestressing materials. "Continuous fiber reinforcing materials" is the general term for unidirectional reinforcing

materials formed by impregnating continuous fibers with fiber adhesive which is allowed to harden, for the purpose of using them to reinforce concrete, or for bundled or woven continuous fibers only.

External cable method:

Placement of prestressing materials on the outside of the concrete to apply tensile force to the members through the anchorage section or deviator in order to achieve the required performance improvement.

External cables:

Of the concrete prestressing steel or continuous fiber prestressing materials, those prestressing materials that can be used for the external cable construction method in which the prestressing materials are placed on the outside of the concrete.

Internal cables:

Of the concrete prestressing steel or continuous fiber prestressing materials, those prestressing materials that are placed on the inside of the concrete. These are categorized as bonded or unbonded depending on whether or not they are bonded to the concrete.

Anchorage section:

The section in which anchorage components are fastened to the concrete members to transmit the prestressing force. These are made up of the anchorage components and the members that are used to fasten them.

Deviator:

The section in which deflection components are fastened to the concrete members to transmit, to the concrete members, the partial force from the prestressing that is applied to the external cables. These are made up of the deflection components and the members that are used to fasten them.

Steel plate bonding method:

A method in which steel plates are attached to the outside of the concrete section to make up for insufficiencies in the primary or distribution reinforcement of the existing members; these bond to the existing members to form a composite configuration in order to achieve the required performance improvement. This method is used for bridge decks and almost all other concrete members.

Fiber-reinforced plastic bonding method:

A construction method in which glass fibers, carbon fibers, aramid fibers or other continuous fiber materials (continuous fiber sheets, etc.) are bonded to the outside of the concrete section, bonding to the existing members to form a composite configuration, after which an organic or other material coating is applied on top, both to prevent the entry of carbon dioxide, chloride ions, moisture etc. and to provide the necessary performance improvement. This method is used for bridge decks and almost all other concrete members.

Steel plate jacketing construction method:

A construction method in which steel plates are placed continuously around the entire periphery of the existing column members, etc. that have insufficient load-carrying capacity, bonding to the existing members to form a composite configuration in order to achieve the required performance improvement. This method is used for bridge piers, etc.

Fiber-reinforced plastic jacketing construction method:

A method in which continuous fiber sheets or other fiber materials are placed continuously around the entire periphery of existing column members, etc. with insufficient load-carrying capacity, bonding to the existing members to form a composite configuration in order to achieve the required performance improvement. This method is used for bridge piers, etc.

Continuous fiber sheet:

Reinforcing materials with continuous fibers arranged in one direction or both directions to form a sheet. Alternately, fiber-reinforced plastics formed by impregnating continuous fibers with impregnation adhesive which is then allowed to harden.

Upper surface overlaying construction method:

A method that does not use steel reinforcement but involves cutting and cleaning the upper surface of the deck and then laying steel fiber reinforced concrete to increase the thickness of the deck in order to achieve the required performance improvement.

Steel reinforced upper surface overlaying construction method:

A variation on the upper surface overlaying construction method, in which the deck is retrofitted by placing steel reinforcement on the overlaying layer and then laying steel fiber reinforced concrete to increase the thickness of the deck in order to achieve the required performance improvement.

Lower surface overlaying construction method:

A method in which steel reinforcement or other reinforcing material is placed mainly on the underside of the deck and then overlaying material, primarily highly adhesive mortar, is applied by troweling or spraying to add thickness and bond in order to achieve the required performance improvement.

Lower surface spray method:

A method in which steel reinforcement is placed on the underside of a deck and then overlaying material, primarily super-quick hardening steel fiber reinforced mortar, is sprayed on to ensure that the steel reinforcement is covered and bonded to the existing deck, in order to reduce the stress and deflection of the existing reinforcement and achieve the required performance improvement.

Reinforced concrete jacketing construction method:

A method in which steel reinforcement is placed around the existing members and concrete is added to increase the number of sections and achieve the required performance improvement.

Mortar spray method:

A method in which lateral ties, spiral reinforcement or the like are applied to the existing members and mortar is sprayed to bond them together in order to achieve the required performance improvement.

Precast panel jacketing construction method:

A method in which precast panels with lateral ties or the like inside are placed around the perimeter of the column and fastened with joint dowels or the like, and the gaps between the column and panels are filled with grout to bond them, in order to achieve the required performance improvement.

Cement-based reinforcing materials:

Cement-based composite materials (concrete/mortar) used as overlaying reinforcements.

CHAPTER 2 FUNDAMENTALS OF RETROFIT

2.1 General

In retrofitting, the structure must be designed so it is in keeping with its purpose of use and is both safe and durable, with consideration given to the ease of retrofitting construction and post-retrofitting maintenance, as well as overall economy and environment-friendliness.

[Commentary]

The design requirements in the text must be fulfilled for both new and repaired structures.

As indicated in the text, structures have a variety of performance requirements. Of these performance requirements, retrofitting of structures is performed to improve performance that is directly related to mechanical characteristics. Therefore, methods for quantitative verification of these performance requirements are noted in these (draft) guidelines. **Table C2.1.1** shows the performance requirements that generally relate to mechanical characteristics of structures.

Table C2.1.1 Performance related to the mechanical characteristics of structures

Performance Category	Description
Safety	Performance needed to ensure that the structure does not threaten the lives of users or persons in the surrounding area
Serviceability	Performance such that the structure can be used comfortably and does not cause discomfort exceeding allowable levels to users of the structure and persons in the surrounding area, as well as watertightness and other performance requirements for structures
Restorability	Performance such that the performance can be easily restored if damage is suffered during the service life

The performance that the structure to be retrofitted should possess during its remaining service life after retrofitting is prescribed according to the type of structure, purpose of use, degree of importance and other factors. Also, since "durability" is the structure's resistance to a drop in various performance values, it is related to all performance through time, and so "durability" is not included in **Table C2.1.1**.

In order to evaluate the performance of a structure and verify that it fulfills its performance requirements, it is necessary to express performance in terms of quantifiable physical quantities that represent performance. For example, safety with respect to failure is verified by means of such indices as flexural load-carrying capacity of members, shear capacity, torsional capacity and so on. The indices to be used may depend on the performance evaluation technology being employed. These (draft) guidelines contain calculation methods for indices that can be evaluated using existing technologies. Ideally, technological progress will make it possible to use more advanced methods and enable verification using indices that can express performance values more directly. **Table C2.1.2** shows sample indices when the evaluation methods generally used today are employed to evaluate the safety, serviceability and restorability of structures, as well as when more detailed performance evaluation methods expected to be possible in the future are used.

Table C2.1.2 Sample indices used for performance verification

Performance and Performance Item		Index when general performance evaluation method is used with existing technologies	Index when more precise performance evaluation method is used
Safety	With respect to failure and collapse	Flexural load-carrying capacity, shear capacity, torsional capacity, various types of fatigue capacity, ductility, etc.	Deformation and failure of structure with respect to anticipated load action (evaluation and verification of structure's response to load through numerical simulations)
	With respect to rigid body safety	Resistance moment with respect to toppling	
Service-ability	Driving and walking comfort	Deflection, rigidity, levelness of road surface, level differences, vibration characteristics of structure and foundation, values for speed, acceleration, vibration level and sound level transmitted to drivers and pedestrians, etc.	Perceptions of users and neighbors produced by the response of the structure to anticipated load action and environmental action (conduct evaluation and verification of the interaction between the response of the structure and the perceptions of human beings)
	Resistance to vibration		
	Resistance to noise		
	Appearance		
	Visual stability		
Restorability		Residual displacement, residual crack width, degree of damage to concrete, etc.	Deformation and failure of structure with respect to anticipated load action

2.2 Flow of Retrofitting Process

Retrofitting of structures shall proceed as follows:

- (1) Identify the performance requirements for the existing structure to be retrofitted and draft an overall plan from inspection through selection of retrofitting method, design of retrofitting structure and implementation of retrofitting work.
- (2) Inspect the existing structure to be retrofitted.
- (3) Based on the results of the inspection, evaluate the performance of the structure and verify that it fulfills performance requirements.
- (4) If the structure does not fulfill performance requirements, and if continued use of the structure through retrofitting is desired, proceed with design of the retrofitting structure.
- (5) Select an appropriate retrofitting method and establish the materials to be used, structural specifications and construction method.
- (6) Evaluate the performance of the structure after retrofitting and verify that it will fulfill performance requirements.
- (7) If it is determined that the retrofitting structure will be capable of fulfilling performance requirements with the selected retrofitting and construction methods, implement the retrofitting work.

[Commentary]

Figure C2.2.1 shows a flow diagram of the retrofitting process. This flow is based on the "General approach to maintenance" in the (draft) Maintenance Guidelines, with the portions dealing with retrofitting extracted and matters pertaining specifically to retrofitting added.

- (2) Inspections of structures to be retrofitted correspond to the "detailed inspections" in the (draft) Maintenance Guidelines. These should be performed in particular to determine whether or not retrofitting

should be performed and gather data needed for retrofitting. Inspections should be performed in accordance with Chapter 5 in these (draft) guidelines and the (draft) Maintenance Guidelines.

(3) The primary criteria for determining whether or not retrofitting should be performed is whether the structure fulfills performance requirements at the time of the retrofitting study. The performance of the existing structure should be verified using methods shown in the Standard Specification (Design) (Seismic Design). However, unlike new structures, with retrofitted structures actual measured values based on the results of inspections can be used for the properties of materials in the structure, section specifications and the like. Accordingly, safety factors used to compensate for uncertainties in the design of new structures can be changed for the retrofitting structure. Also, the effect of such factors as damage to the structure or loss of steel cross-sectional area due to corrosion or the like must be considered when necessary. The method used to determine the design values for the materials in the existing structure is shown in Chapter 3 of these (draft) guidelines.

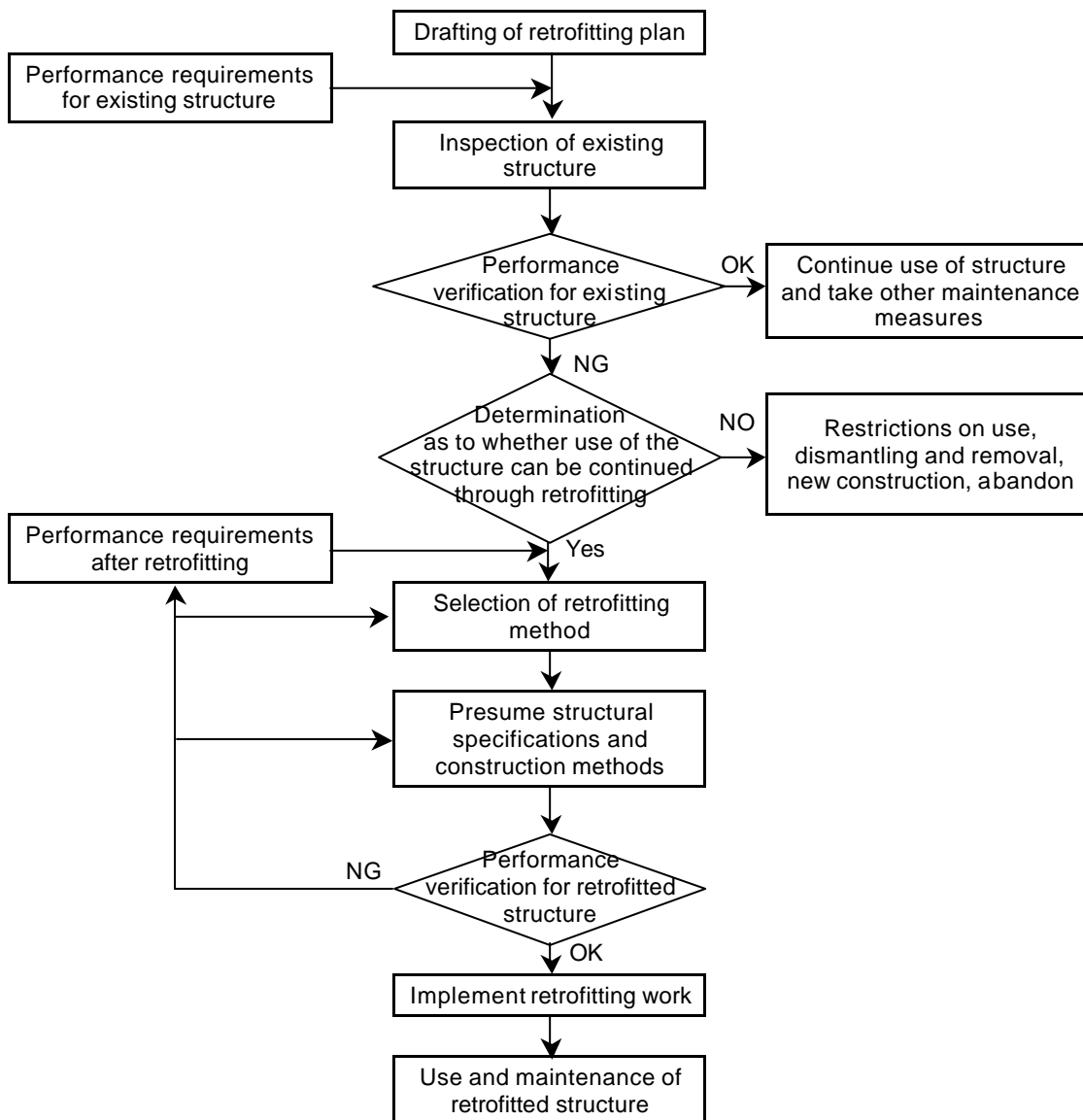

Figure C2.2.1 Flow of retrofitting process

(4) If it is determined through performance evaluation and verification that the existing structure does not fulfill performance requirements, and that use of the structure can be continued through retrofitting, the design process should proceed. In some cases, the performance requirements for the structure after retrofitting will not be the same as those of the existing structure.

Retrofitting of structures includes the following cases:

- (i) The performance requirements are the same as those of the structure when it was first built, but because the performance of the structure has declined due to load action and environmental action over time, the structure did not fulfill performance requirements at the time of the inspection; through retrofitting, the performance that would satisfy performance requirements is added.
- (ii) The design load has been changed or the structure otherwise requires a higher level of performance than when initially constructed, and therefore it does not fulfill performance requirements; through retrofitting, the performance that would satisfy performance requirements is added.
- (iii) At the time of the inspection, the structure fulfilled performance requirements but is predicted to not do so in the future due to a decline in performance due to load action and environmental action over time; performance improvements are conducted to prevent this in advance.

Figure C2.2.2 contains a diagram illustrating these cases. In cases (i) and (iii), a higher level of performance than the structure when first built may be added, or the structure may be restored to the same performance level, or performance at a lower level than the structure when first built, but still satisfying performance requirements, may be added (**Figure C2.2.2** uses case (i) as an example).

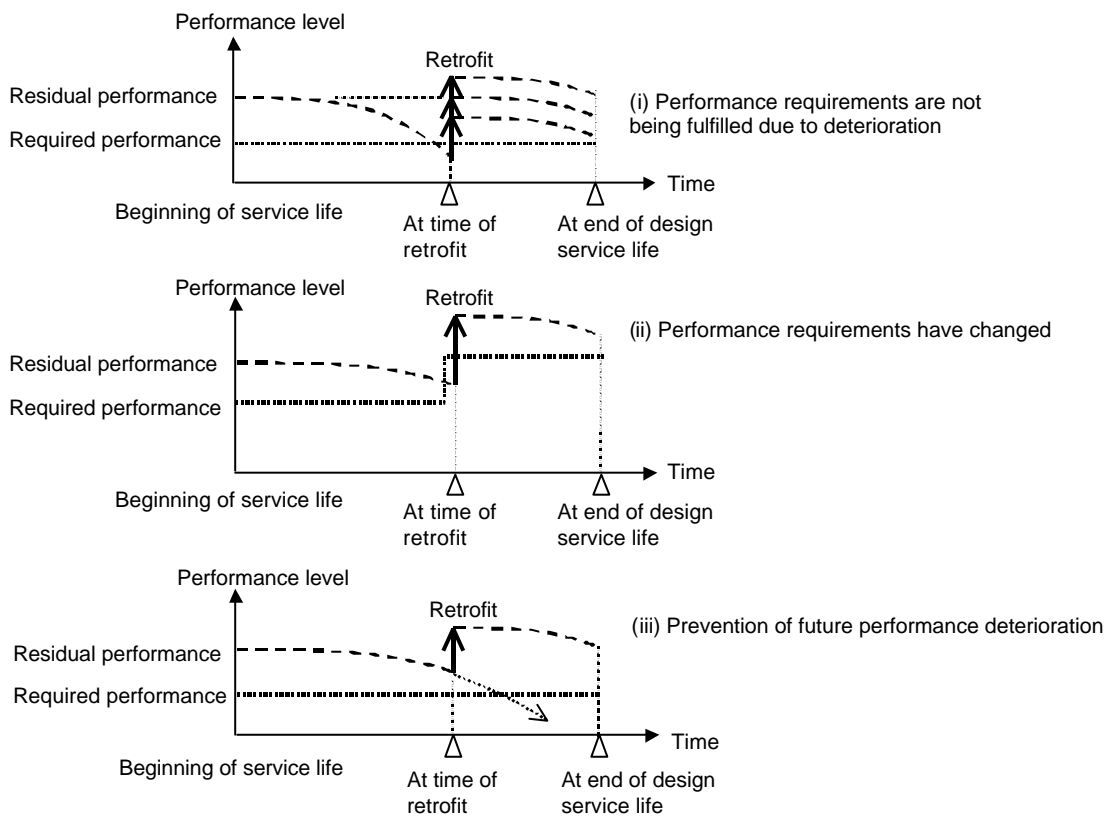

Figure C2.2.2 Performance improvement through retrofitting

(5) A viable retrofitting method is selected in accordance with the type of structure being retrofitted, the use conditions, the type and degree of performance to be improved, and so on. Chapter 7 in these (draft) guidelines covers general matters pertaining to the selection of the retrofitting method, primarily the external cable construction method, bonding and jacketing construction method, and overlaying and jacketing construction method. Design considerations when conducting retrofitting using these construction methods are shown in the retrofitting manuals.

(6) A check is conducted to confirm that the structure retrofitted with the selected retrofitting method will fulfill performance requirements after retrofitting at all points throughout its remaining design service life. Changes over time in the performance of retrofitted structures should be considered in design, in accordance with the principles shown in Section 2.3 in this chapter.

(7) Considerations for construction using the external cable construction method, bonding and jacketing construction method, and overlaying and jacketing construction method are shown in the retrofitting manuals.

2.3 Changes over Time in Performance of Retrofitted Structures

(1) In the design of retrofitted structures, it must be confirmed that the retrofitted structure will fulfill performance requirements after retrofitting at all points throughout its remaining design service life. When the performance requirements remain constant over time, based on the fact that the performance of a structure generally deteriorates over time, verification assuming the end of design service life may be performed in place of overall design life verification.

(2) When the changes over time in the performance of the retrofitted structure during its service life due to load action and environmental action cannot be predicted with sufficient reliability, one of the following methods must be used.

- (i) Select retrofitting materials, structural specifications and construction methods such that there will be no decline in the performance of the structure over time in real terms.
- (ii) Select retrofitting materials, structural specifications and construction methods such that the decline in performance will only be to the extent predictable with existing prediction technologies.
- (iii) Devise measures to conduct maintenance during the service life after retrofitting to ensure that the performance will not go below performance requirements.

[Commentary]

(1) **Figure C2.3.1** shows the ideal manner in which performance verification for retrofitted structures should be performed. During use, the status of the structure (characteristics of materials in the structure, accumulated damage, structural aspects) will change over time due to load action and environmental action. As the performance of a structure at each point in time will be achieved by the result of these factors, the performance exhibited will also change over time. Accordingly, to verify the performance of the structure after retrofitting at a future point in time, ideally the changes experienced by the structure over time under the assumed load action and environmental conditions should be predicted and, based on the results, the performance at the point in time being verified should be evaluated and verified against the performance requirements.

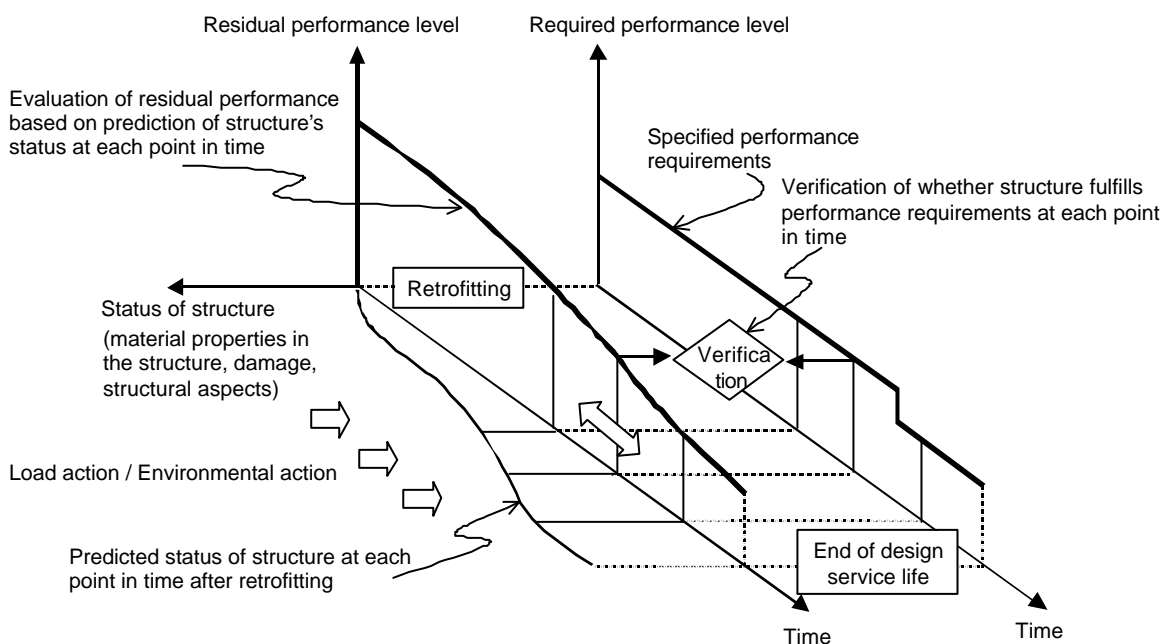

Figure C2.3.1 Performance verification of structure along time axis

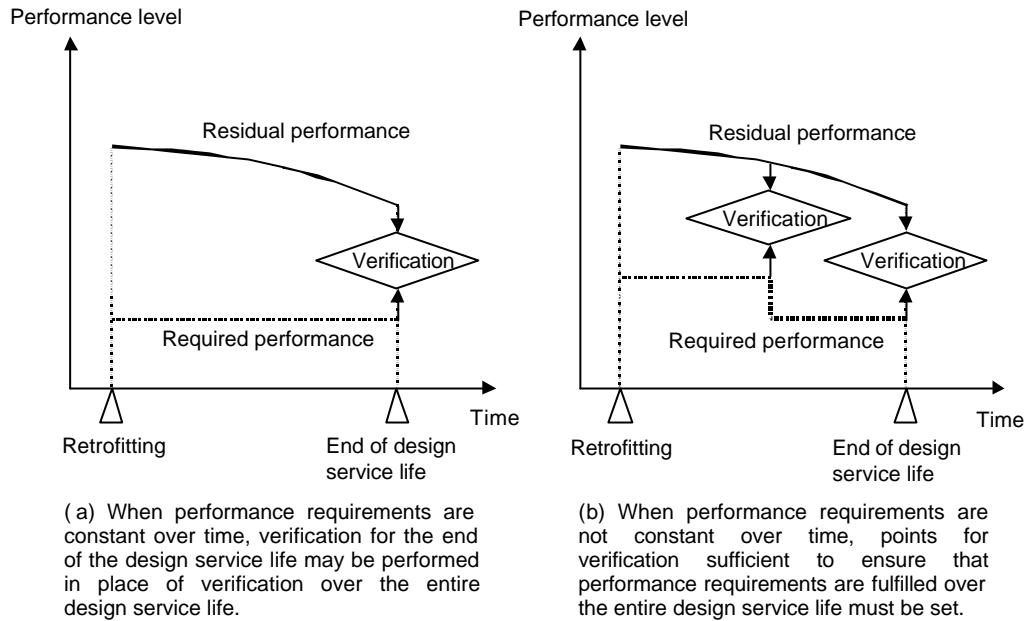

Figure C2.3.2 Approach to setting verification points for performance of retrofitted structures

When the required level of performance for the structure after retrofitting is constant over time, the performance of the structure at the end of its design service life may be evaluated and fulfillment of performance requirements confirmed rather than performing verification over the entire design service life. This approach uses the fact that the performance of structures generally experiences monotonic decrease over time due to load action and environmental action during use. It cannot be used when performance requirements change over time (see Figure C2.3.2). With this method, it is not necessary to make a minute evaluation of changes over time in the performance of the structure, just the performance at the end of the design service life.

(2) Currently, these are the methods generally used to deal with changes over time in the performance of structures. Considerations relating to materials when these methods are used with the external cable construction method, the bonding and jacketing construction method and the overlaying and jacketing construction method are noted in Chapter 3 of these (draft) guidelines. Considerations relating to design and construction are noted in the retrofitting manuals.

Chapter 3 Materials

3.1 General

This chapter shall cover the method of determining design values for the materials used in existing structures to be retrofitted, and the method of determining design values and quality requirements for the materials used with the external cable construction method, the bonding and jacketing construction method and the overlaying and jacketing construction method.

[Commentary]

The characteristics of materials in existing structures to be retrofitted may differ from those assumed when the structure was first designed and built, due to various factors at the construction stage as well as load action and environmental action during use. In retrofitting design, this must be considered and the design values for the materials in existing members must be determined. Even materials not covered here should be verified for quality before use.

3.2 Materials in Existing Structures

The design values for materials in existing structures used for retrofitting design shall be determined in accordance with inspection results.

(1) Characteristic values

The characteristic values for materials in the existing structure, after consideration of the variations in measurements obtained through inspections, shall be those that ensure that most of the measurements will not fall below those values. When sections are missing due to corrosion or the like, the cross-sectional area for steel shall be determined using measurements or recommended values calculated with appropriate methods.

(2) Material factors

As a rule, the material factors for materials in the existing structure shall be determined in accordance with the Standard Specification. When the characteristics of materials in the existing structure are different from those assumed at the time the structure was first built, or when the status of use after retrofitting will be different, material factors apart from the values in the Standard Specification shall be determined.

[Commentary]

(1) Characteristic values are determined by the distribution of test values and the likelihood that test values lower than the characteristic value will be obtained. In the Standard Specification, the explanation uses the example of a likelihood of 5%. As a rule, characteristic values are determined in the same manner for the materials in existing structures. However, in general there are few sample test values from inspections and it is difficult to identify the distribution of test values. Accordingly, here it was decided to make an overall judgement of inspections to estimate characteristic values.

The characteristic value for the tensile strength of steel is not thought to be dependent on time, but tensile strength will vary due to a reduction in cross-sectional area. To reflect this in design, here it was decided to consider changes in the cross-sectional area of the steel used in the existing structure. Other characteristic values relating to steel must be determined based on the status of corrosion, past stress history and other factors. When the steel has been subjected to considerable corrosion and a history of stresses exceeding the yield strength, it must be noted that the bond properties, fatigue properties, elongation properties and the like will have changed.

(2) Material factors for new construction and those for retrofitting are different. Material factors for newly built structures are determined based on the purpose of use, design service life, load and environmental conditions, construction/maintenance and other factors. Material factors for retrofitting design, however, should be determined through consideration of the load and environmental conditions, material characteristics, design service life after retrofitting and other factors that have been determined through inspections. If the status of the existing structure determined through inspections is the one assumed in the design, the material factors may be determined in accordance with the Standard Specification.

In general, the specified design strength was used as the characteristic value for the compressive strength of the concrete used in new structures, and the design value was derived by dividing this value by the material factor. The characteristic value for the concrete in the existing structure was known from inspections, reducing the uncertainty, and for this reason the material factor could be reduced. When determining the flexural strength, tensile strength, bonding strength, bearing strength and other characteristic values for concrete materials from the characteristic value for compressive strength, in accordance with Section 3.2 in the Standard Specification (Design), the status of deterioration of the concrete materials must be observed and the material factors handled carefully.

3.3 Quality of Materials

3.3.1 External Cables

- (1) The quality of external cables shall be indicated by the tensile strength and other strength properties, Young's modulus and other deformation properties, and thermal properties and other material characteristics.
- (2) As a rule, external cables shall be protected using protective tubes or rustproofing materials, and their quality shall be protected with suitable means so it does not change over time.
- (3) Anchoring and connecting components must have a configuration and strength suitable to prevent them from experiencing failure or remarkable deformation below the standard values or characteristic values for the tensile load of the anchored or connected external cables.

[Commentary]

(1) External cables must have the quality enabling them to introduce and maintain the required prestressing force. The quality of external cables is generally indicated by tensile strength and other strength properties, Young's modulus and stress-strain relationship, creep properties and other deformation properties, coefficient of linear expansion and other temperature properties, relaxation properties, and so on. Accordingly, external cables that clearly possess the strength, elongation capacity, Young's modulus, creep failure resistance, coefficient of linear expansion and other values that can be relied upon from an engineering standpoint must be used.

When concrete prestressing steel is used for external cables, prestressing wires and stranded prestressing wires should conform to JIS G 3536, and prestressing bars should conform to JIS G 3109 and 3137; equivalents may also be used. When prestressing steel that has been rustproofed in advance is used, it must be confirmed as having the required quality. Also, when continuous fiber prestressing materials are used, as a rule those that conform to JSCE-E 131 "Quality Standards for Continuous Fiber Reinforcing Materials (draft)" (Japan Society of Civil Engineers) must be used. When continuous fiber prestressing materials that do not conform to JSCE-E 131 are used as external cables, they must be confirmed as having the specified quality.

The tensile properties of external cables must include fretting fatigue strength. Fretting fatigue generally refers to the fatigue of flexurally placed prestressing materials and must be distinguished from linearly placed materials.

(2) The quality of external cables is thought to change as a result of the intrusion of substances that accelerate steel corrosion, the action of chemical substances, the action of ultraviolet light, the action of friction at deviators and other factors during their service life. Also, the strength or other quality properties of continuous fiber prestressing materials may decline if they are scratched or otherwise damaged during construction. If the external cables ultimately break due to a decline in quality, the safety of the structure may be impaired and result in danger to human life, so this must be avoided.

With the development of rustproofing technologies for the prestressing steel for external cables, in recent years rustproofed materials have been used to prevent steel corrosion, or protective tubes or a combination of protective tubes and rustproofed materials have been used to enable external cables to be placed in an environment where they will not be affected by chemical substances or ultraviolet light. For these reasons, it was decided that, when external cables are used, suitable methods must be implemented to protect external cables from actions or environments that might cause their quality to change over time, in principle. However, this condition need not be observed if it can be confirmed from the results of appropriate

numerical tests and accelerated exposure tests that the quality of the external cables does not change over time even if they are not protected, or if the decline in quality can be accurately predicted.

The protective tubes and rustproofing materials used to protect external cables must have the following properties.

(i) Protective tubes

Protective tubes are used to protect external cables and as fill tubes for rustproofing material. The protective tubes used must have the following properties:

1. Protective tubes must have sufficient rigidity and strength so they will not be damaged during transport, member attachment, tension work and rustproofing material fill work. They must also have sufficient strength to withstand long-term contact pressure at deviators.
2. Protective tubes must be made of a material that will not cause a chemical reaction with the fill material and must be strong enough to withstand the fill pressure.
3. Protective tubes must have adequate chemical stability in the anticipated temperature range for construction and use. For example, if the reaction of the protective tube to temperature is too sensitive, leakage of fill material or other unexpected accidents may result. Accordingly, study of the coefficient of thermal expansion for each material is needed.
4. When considering the replacement of external cables, a type of material that will make replacement work easy must be selected.

In general, steel pipes, polyethylene tubes, polypropylene tubes, metal-reinforced polyethylene tubes and fiber-reinforced plastics are used as protective tubes. The use of polyethylene tubes appears to be particularly common. Polyethylene tubes that conform to JIS K 6761 (general use) and JIS K 6762 (water) should be used. In recent years, high density polyethylene tubes have often been used.

(ii) Rustproofing materials

If rustproofing is a primary objective for protection when prestressing steel is used for external cables, a rustproofing material must be used to protect the external cables. The specific methods listed below are used to rustproof external cables. However, whichever method is used, it must be able to provide sufficient rustproofing performance until the end of the structure's service life.

1. Bare wire rustproofing (galvanizing, coating with epoxy resin, polyethylene sheath, etc.)
2. Fill (cement grout, grease wax, bituminous material)
3. Combination of 1 and 2

When using prestressing wires by themselves, without a protective tube, after they have been galvanized, coated or covered with a sheath, they should be maintained in a satisfactory state so they will not be greatly affected by the environment or chemical action. Moreover, a decline in quality through chemical action of the rustproofing material or changes over time will have a great affect on the quality of external cables, so their material properties must be ascertained and it must be confirmed that they will not react with the materials with which they come in contact.

(3) As a rule, the quality of anchoring and connecting components must be confirmed in accordance with JSCE-E 503 "Methods for Testing the Performance of Anchoring and Connecting Components for Prestressed Concrete Construction" (draft) (Japan Society of Civil Engineers) and JSCE-E 537 "Methods for Testing the Performance of Anchoring and Connecting Components for Prestressed Concrete Construction Using Continuous Fiber Reinforcing Materials" (draft) (Japan Society of Civil Engineers).

3.3.2 Steel Plates

- (1) The quality of steel plates shall be indicated by their tensile strength and other strength properties, Young's modulus and other deformation properties, and thermal properties and other material characteristics. Steel plates must be those for which weldability and bonding with adhesives can be ensured when necessary.
- (2) The surface of steel plates must be suitably protected to prevent their quality from changing over time.

[Commentary]

(1) SS 400 is a standard material used for steel plates. When SS 400 is used, it should have a JIS standard certificate. When welded joints are used to connect steel plates, the weld must be one for which the required strength can be ensured. When an adhesive is used to bond the steel plate to the concrete surface, one whose adhesive properties will enable the required bonding strength to be secured must be used. When steel plates of a material other than SS 400 are used, a separate study of bonding properties and weldability must be conducted when necessary.

(2) In general, the quality of steel plates will change over time through load action and environmental action. With the bonding method, steel plates are generally placed on the outer surface of the reinforced concrete members, so they tend to be affected by changes over time that result from corrosion caused by environmental action. As an anticorrosion measure for steel plates, in general, etching primer and zincrich primer are used; a material whose anticorrosion, adhesion and other quality requirements have been confirmed should be coated with a suitable coating thickness.

3.3.3 Continuous Fiber Sheets

(1) The quality of continuous fiber sheets shall be indicated by their tensile strength and other strength properties, Young's modulus and other deformation properties, and thermal properties and other material characteristics.

(2) As a rule, the surface of continuous fiber sheets shall be protected to prevent their quality from changing over time.

[Commentary]

(1) Continuous fiber sheets must be checked to confirm that they possess the strength, elongation capacity, Young's modulus, coefficient of linear expansion and material properties that can be relied upon from an engineering standpoint. Moreover, the quality of continuous fiber sheets will change depending on the resin with which they are impregnated and bonded, so the material properties of the continuous fiber sheets and the fiber-reinforced plastic composite material used for impregnating and bonding must be confirmed.

(2) In general, the quality of continuous fiber sheets will change over time due to load action and environmental action. With the bonding method, the continuous fiber sheets are placed on the outer surface of the structure, so as a rule a protective layer of paint, concrete, mortar or the like must be provided to prevent the reinforcing materials from changing over time. However, this condition need not be observed if it can be confirmed from the results of appropriate numerical tests and accelerated exposure tests that the quality of the continuous fiber sheets does not change over time even if they are not protected, or if the decline in quality can be accurately predicted.

3.3.4 Adhesive

(1) The adhesive used to bond the concrete and reinforcing material must be one that can ensure the required bonding strength.

(2) The adhesive used for the overlap splices for the reinforcing material must be one that can ensure the strength of the overlap splice section.

(3) The impregnation/adhesive agent used for the continuous fiber sheet bonding method must be one that ensures the strength, Young's modulus and other quality requirements of the continuous fiber sheets as a fiber bonding material.

(4) The adhesive must be one with suitable viscosity, shrinkage and other characteristics in keeping with the coating, fill or other construction method.

[Commentary]

(1) In performance verification, when surface holding is assumed, the reinforcing material must be bonded to the concrete by the adhesive. The bonding strength of the concrete and reinforcing material will vary depending on the type of adhesive and reinforcing material, the nature of the concrete surface and other factors, so suitable tests should be performed to check the bonding strength.

- (2) The adhesive used for the overlap splices using steel splice plates and the lap splices for the continuous fiber sheets must have a bonding strength sufficient to enable the required overlap splice strength to be obtained.
- (3) The continuous fiber sheet must have resin well impregnated between the continuous fibers to join the fibers to one another and transmit stress, in order to enable the sheet to function as a fiber-reinforced plastic with the proper strength, Young's modulus and other quality requirements. Accordingly, the impregnation/adhesive agent must function as an adhesive that bonds the reinforcing material to the concrete, as well as being able to ensure the strength, Young's modulus and other quality requirements for continuous fiber sheets as a fiber bonding material for fiber-reinforced plastics.
- (4) With the bonding method, the structure is retrofitted at the site by using adhesive to bond the reinforcing material to the concrete. Accordingly, the adhesive must have viscosity, fluidity and other quality values suitable for site construction.

3.3.5 Fill Material

- (1) The fill material used with the jacketing method must have the required fill properties and fluidity and must be able to seal the reinforcing material to the concrete.
- (2) The fill material must form a thick hardening body and must transmit stress effectively between the reinforcing material and the concrete frame.

[Commentary]

- (1) When using the jacketing method to improve the shear capacity and ductility of bar members, it is not always necessary to bond the reinforcing materials to the existing concrete; it is only important that the reinforcing materials and the existing concrete be sealed together. The fill material must have fill properties and fluidity that are appropriate for the interval between the reinforcing materials and the concrete and the injection method.

3.3.6 Cement-Based Reinforcing Material

- (1) The quality of cement-based reinforcing material shall be indicated by the compressive strength, tensile strength and other strength properties, Young's modulus and other deformation properties, and thermal properties, watertightness and other material properties needed to evaluate the performance of the retrofitting structure.
- (2) As a rule, good quality materials shall be selected for use in cement-based reinforcing materials, and trial mixing using an appropriate mixing design method shall be performed to determine the ideal mixture, so there will be as little change as possible in the quality over time after hardening.

[Commentary]

- (1) Here cement-based reinforcing material refers to mortar, concrete and other materials. The quality requirements for these reinforcing materials will differ depending on the type and level of performance required for the retrofitted structure. Currently, the materials used with the overlaying and jacketing methods differ depending on the target method, and suitable types and quality of materials are used. Here, the reinforcing materials currently being used will be covered, but this is not meant to prevent the use of other reinforcing materials. Cement-based reinforcing materials must have little drying shrinkage and must attain practical strength quickly, and they also must have excellent cracking resistance and flexural and shear properties. Furthermore, they must also have excellent fatigue resistance when used with the upper surface overlaying method, steel reinforced upper surface overlaying method, lower surface overlaying method and lower surface spray method to reinforce bridge decks. With the lower surface overlaying method, cement-based reinforcing materials are applied to the underside through human labor and must bond to existing members, so they must have particularly excellent bonding properties.

In general, with the upper surface overlaying method and steel reinforced upper surface overlaying method, stiff-consistency steel fiber reinforced concrete utilizing ultra-quick hardening cement and high early strength Portland cement and other high early strength cements is used. With the lower surface overlaying method, polymer mortar with high bonding strength is used, while with the lower surface spray method steel

fiber reinforced spray mortar utilizing ultra-quick hardening cement and the like are used. Steel fibers that fulfill the quality requirements in JSCE-E 101-1983 (SFRC guidelines) "Quality standards for steel fibers for concrete" should be used. With the reinforced concrete jacketing method, it is important to make sure no voids are created in the overlaying section, so flowing concrete with a slump of approximately 18 cm is used, in some cases together with an expansion material to reduce drying shrinkage. In the mortar spray method, the overlaying section formed by the spray mortar is thin, and so the mortar must have high fill properties and cracking resistance; accordingly, cement mortars that use expansion materials or cement mortars containing short plastic fibers are used. In addition, since after spraying the surface is finished with a metal trowel, the mortar must be of a type that will make troweling work easy. As a rule, the reinforcing material used with the precast panel jacketing method should be concrete containing lateral ties and joints or precast panels made of mortar. Gaps between the existing concrete and the precast panels must be filled with highly fluid grout mortar.

The quality of reinforcing materials is indicated by material properties such as compressive strength, tensile strength and other strength properties, Young's modulus and Poisson's ratio, and stress-strain relationship and other deformation properties. Reinforcing materials must be checked to make sure they have the strength, elongation capacity, Young's modulus, coefficient of linear expansion and other material properties that can be relied upon from an engineering standpoint. The quality of cement reinforcing materials is indicated not only by compressive strength but by a variety of material properties. Strength properties are indicated by compressive strength, tensile strength, flexural strength, bonding strength and other static strength as well as fatigue strength. With the overlaying and jacketing method, bonding strength and fatigue strength are important material properties. Also, in addition to the Young's modulus and Poisson's ratio, indicators of ductility, cracking resistance and other dynamic properties may also be required as deformation properties for the overlaying and jacketing method. Nevertheless, generalized numerical handling methods for these properties have not yet been established and are still at the research stage.

(2) Cement-based reinforcing materials are generally provided as ready mixed concrete or are mixed at the site. The quality of fresh concrete between the time that mixing is complete until it is laid will affect not only work performance but the material properties of the hardened concrete accompanying changes over time. Accordingly, the mixing conditions must be established and trial mixing performed to check the quality by means of the slump, air content, compressive strength and other material properties, in order to ensure that the required properties for hardened concrete are attained. It is also important to select good quality materials so alkali aggregate reaction and other problems with materials do not occur.

When appropriate testing and analysis have confirmed that the compressive strength and other material properties of cement reinforcing materials, which have been created with an appropriate mix design through the use of good quality materials, will exhibit almost no change over time, the material properties at the time of verification may be used as the properties for retrofitting construction. In the overlaying and jacketing method, the reinforcing materials are placed on the outer surface of the structure, so protection or the like should be applied to the retrofitted members in order to prevent changes in the reinforcing materials over time. When changes in the material properties over time can be prevented through suitable protection, the material properties at the time of verification may be used as the properties for retrofitting construction.

In selecting the materials to be used and determining the mix design, reference should be made to the following Standard Specifications and guidelines.

- Standard Specification for Concrete (Design) (Construction) (Japan Society of Civil Engineers)
- Concrete Overlaying Method manual (among the individual methodology manuals) in Concrete Engineering Series No. 28 "The Future of Retrofit Design and Construction for Concrete Structures - Retrofit Design Guidelines with Performance Verification (draft)" (Japan Society of Civil Engineers) 1998
- "Guidelines for Steel Fiber Reinforced Concrete Design and Construction (draft)" (Japan Society of Civil Engineers) 1983
- Upper surface overlaying method design and construction manual (Express Highway Research Foundation of Japan) 1995
- Design Procedures, Second Edition (Japan Highway Public Corporation) 1997
- Design/Construction Guidelines for Seismic Retrofitting of Existing Concrete Railway Viaduct Piers, etc.
 - Spiral reinforcement jacketing construction method (Railway Technical Research Institute) 1996

- Design/Construction Guidelines for Seismic Retrofitting Method for Viaduct Piers using Spray Mortar (Railway Technical Research Institute) 1996
- Design/Construction Guidelines for Seismic Retrofitting of Existing Concrete Railway Viaduct Piers, etc.
 - Precast reinforced concrete mold construction method (Railway Technical Research Institute) 1996

3.3.7 Steel

The quality of steel used together with cement reinforcing materials shall be indicated by the compressive strength, tensile strength and other strength properties, Young's modulus and other deformation properties, and thermal properties, watertightness and other material properties needed to evaluate the properties of retrofitted structures.

[Commentary]

Here steel refers to reinforcing steel used together with cement reinforcing materials. This includes both steel reinforcement and prestressing steel as well as the steel, etc. used to anchor and connect these materials. These reinforcing steel materials should fulfill the quality standards noted in JIS standards.

3.4 Material Characteristic Values and Design Values

3.4.1 External Cables

- (1) Characteristic values and design values for external cables must be derived using appropriate methods.
- (2) Characteristic values and design values for prestressing steel shall be determined in accordance with the Standard Specification (Design).
- (3) Characteristic values and design values for continuous fiber prestressing materials shall be determined in accordance with the "Recommendation for Design and Construction of Concrete Structures Using Continuous Fiber Reinforcing Materials (draft)" (Design).
- (4) Material factors for external cables shall be determined in accordance with Section 2.6 (2) in the Standard Specification (Design) and Section 2.6 in the "Recommendation for Design and Construction of Concrete Structures Using Continuous Fiber Reinforcing Materials (draft)" (Design).

[Commentary]

- (2) When using prestressing steel that conforms to JIS standards, the characteristic values and design values for external cables should be determined in accordance with Section 3.3 of the Standard Specification (Design). The external cables that can generally be used are shown by anchoring method in the Recommendation for Design and Construction of Structures Using Prestressed Concrete Construction Method (Japan Society of Civil Engineers), so this manual should be used as reference.
- (3) When using continuous fiber prestressing materials that conform to JSCE-E 131 "Quality Standards for Continuous Fiber Reinforcing Materials (draft)," the characteristic values and design values for external cables should be determined in accordance with the "Recommendation for Design and Construction of Concrete Structures Using Continuous Fiber Reinforcing Materials (draft)" (Design) (Japan Society of Civil Engineers).

When using continuous fiber prestressing materials that do not conform to JSCE-E 131 as external cables, tests must be conducted to determine the design values (design strength and Young's modulus), design ultimate strain and other values. In such cases, the tensile strength, flexural tension breakage load, creep failure capacity, relaxation value, fatigue strength, coefficient of thermal expansion, shear strength and other values should be determined through test methods equivalent to those in JSCE-E 531 "Test method for tensile properties of continuous fiber reinforcing materials (draft)" and other Japan Society of Civil Engineers standards. However, even when other test methods are used, these values may be used if it is determined that sufficient performance results exist and the characteristic values (including the effects of anchorage components) can be relied upon. In addition, with the external cable method, the use of the multi-cable system that formerly was not often used with internal cables is expected to become more frequent. The characteristics of the multi-cable system include tensile strength that does not increase

proportionally to the number of multiply anchored stressing components, so a thorough knowledge of the characteristics of this system is needed for it to be used.

(4) **Table C3.4.1** shows the standard material factors for protected external cables. This table should be referred to when determining material factors.

Table C3.4.1 Material factors for external cables

[Objective]	Steel	Continuous fiber prestressing materials
For serviceability verification	1.0	1.0
For safety verification	1.0- 1.05	1.15 - 1.30

3.4.2 Steel Plates

As a rule, characteristic values and design values for steel plates shall be in accordance with Guidelines for the Design of Steel Structures.

[Commentary]

Characteristic values and design values for the tensile strength of steel plates and the stress-strain relationship, Young's modulus and other values should be in accordance with the Guidelines for the Design of Steel Structures (Japan Society of Civil Engineers). When using materials not covered in the Guidelines for the Design of Steel Structures, the strength, Young's modulus, stress-strain relationship, coefficient of thermal expansion and other material characteristic values and design values should be determined through testing.

3.4.3 Continuous Fiber Sheets

- (1) As a rule, characteristic values for the tensile strength of continuous fiber sheets shall be determined through tensile tests.
- (2) Characteristic values for the bonding strength of continuous fiber sheets to concrete shall be determined through appropriate testing.
- (3) Compressive strength and shear strength of continuous fiber sheets shall not be considered in design.
- (4) As a rule, the Young's modulus for continuous fiber sheets shall be determined through tensile tests.
- (5) The tensile stress-strain relationship for continuous fiber sheets used for safety verification shall be assumed through a model consisting of the tensile strength determined through testing and a straight line passing through the ultimate strain point corresponding to this tensile strength value and the origin. The tensile stress-strain relationship for continuous fiber sheets used for serviceability verification shall be assumed through a model containing a straight line passing through the Young's modulus determined through tensile tests at the origin.
- (6) As a rule, the coefficient of thermal expansion for continuous fiber sheets shall be determined through testing.
- (7) The characteristic value for the fatigue strength of continuous fiber sheets shall be determined through appropriate testing.
- (8) The characteristic value for bonding fatigue strength of continuous fiber sheets to concrete shall be determined through appropriate testing.
- (9) The material factors for continuous fiber sheets shall be determined in accordance with Section 2.6 (2) of the Standard Specification (Design).

[Commentary]

(1) Tensile tests should use JIS K 7073 "Test method for tensile properties of carbon fiber strengthening plastic" as a standard. Continuous fiber sheets function as fiber-reinforced plastic in which the continuous fibers are bonded using an impregnation/adhesive agent. Even if the same strengthened fibers are used, the strength of continuous fiber sheets will differ depending on the form of the sheet and its combination with the impregnation/adhesive agent, so measurements should be performed with the continuous fiber sheet in fiber-reinforced plastic form, after it has been impregnated with the impregnation/adhesive agent and allowed to harden (see **Figure C3.4.1**). Variations in the tensile strength of continuous fiber sheets are known to be generally greater than steel, but the distribution can be thought of as an almost perfectly normal distribution. The characteristic value used for tensile strength is generally the average strength minus three times the standard deviation. This is equivalent to a 99.9% confidence limit for tensile strength. The cross-sectional area of only the continuous fibers is generally calculated from the fiber weight and used as the cross-sectional area for calculating the tensile strength of continuous fiber sheets. Here the fiber weight is the mass of continuous fibers included in a unit area of the continuous fiber sheet. The cross-sectional area for the fibers alone can be calculated from this value and the specific gravity of the continuous fibers.

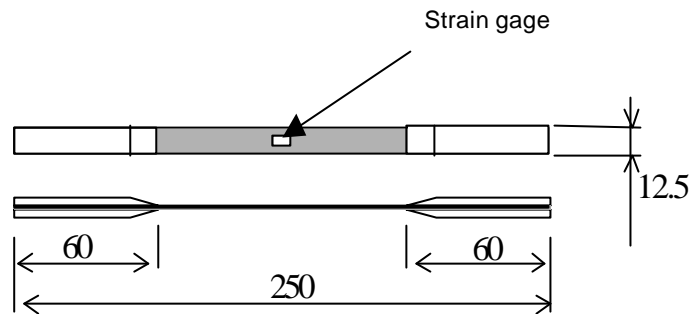

Figure C3.4.1 Sample tension test piece (unit: mm)

(2) The bonding strength of continuous fiber sheets to concrete will differ depending on the type of continuous fiber sheets, the type of adhesive, the strength and surface processing status of the concrete and other factors, so it was decided that, as a rule, this value should be determined through testing. The methods include the one shown in **Figure C3.4.2**, in which continuous fiber sheets were bonded to square columns and tensile force was then applied to the continuous fiber sheets and a tensile shear test was performed for the concrete surface and the continuous fiber sheets. The methods also include one in which continuous fiber sheets were bonded to the surface of a concrete beam test piece on which tensile stress was applied and then a bending test was performed and the bonding strength determined from the peeling load of the continuous fiber sheets. Since the method by which bonding force is transmitted differs depending on whether the continuous fiber sheets are attached to the tensile stress surface or the shear stress surface of the member, the appropriate method should be selected to derive the bonding strength.

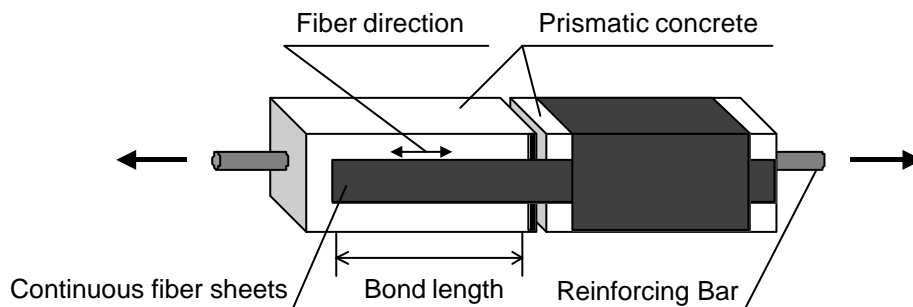

Figure C3.4.2 Sample bonding test piece

- (3) As continuous fiber sheets are extremely thin in comparison with the dimensions of the members, it is difficult for them to bear compressive force. In addition, their shear rigidity and shear strength is extremely low compared to those of steel and concrete. For this reason, the compressive strength and shear strength of continuous fiber sheets are not considered in design.
- (4) As a rule, tensile tests should be in accordance with JIS K 7073 "Test method for tensile properties of carbon fiber strengthening plastic." The Young's modulus of continuous fiber sheets is measured with the continuous fiber sheets in fiber-reinforced plastic status, after they have been impregnated with the impregnation/adhesive agent and allowed to harden. The cross-sectional area used to calculate the Young's modulus for continuous fiber sheets is generally calculated as the cross-sectional area for the continuous fibers alone from the fiber weight.
- (5) The stress-strain curve for continuous fiber sheets will differ depending on the continuous fibers, the shape of the sheet and other factors. In general, the tangential Young's modulus will change depending on the stress level, so a model should be established in accordance with the performance being verified.
- (6) The coefficient of thermal expansion in the fiber direction for continuous fiber sheets will differ depending on the type of continuous fibers, the specific volume of continuous fibers and impregnation/adhesive agent forming the fiber-reinforced plastic composite material, and the method of sheet manufacture, so it was decided that, as a rule, this value should be determined through testing. The coefficient of thermal expansion for continuous fiber sheets should be measured with the sheets in fiber-reinforced plastic form, with the sheets impregnated with impregnation/adhesive agent and allowed to harden. Currently there are almost no sample measurements of the coefficient of thermal expansion for continuous fiber sheets. However, it is known that the coefficient of thermal expansion for unidirectional fiber-reinforced plastic materials can be estimated using **Equation C3.4.1**, from the coefficient of thermal expansion and Young's modulus for the continuous fibers and the matrix resin and the specific volume of continuous fibers.

$$a_L = \frac{E_f \cdot a_f \cdot V_f + E_m \cdot a_m \cdot (1 - V)}{E_f \cdot V_f + E_m \cdot (1 - V_f)} \dots\dots\dots(\text{Equation 3.4.1})$$

where:

- a_L :Coefficient of thermal expansion in fiber direction for fiber-reinforced plastic
- a_f :Coefficient of thermal expansion for continuous fibers
- a_m :Coefficient of thermal expansion for matrix resin
- E_f :Young's modulus for continuous fibers
- E_m :Young's modulus for matrix resin
- V_f :Specific volume of continuous fibers in fiber-reinforced plastic

(7)(8) When determining characteristic values for fatigue strength through testing, the type of continuous fiber sheet, the degree and frequency of applied stress, the environmental conditions and other factors should be considered.

(9) The "Recommendation for Design and Construction of Concrete Structures Using Continuous Fiber Reinforcing Materials (draft)" (Design) notes that the material factor for continuous fiber reinforcing materials may generally be set to 1.15 - 1.3. It is thought that continuous fiber sheets, as fiber-reinforced plastics, may be handled in the same manner as continuous fiber reinforcing materials. Accordingly, when appropriate construction and protection are performed, the material factor for continuous fiber sheets may be set to 1.15 - 1.3.

3.4.4 Cement-Based Reinforcing Materials

- (1) Concrete

The characteristic values and design values for concrete shall conform to Section 3.2 in the Standard Specification (Design). Characteristic values and design values for materials not covered by the Standard Specification shall be determined through appropriate testing.

(2) Mortar

- (i) As a rule, the characteristic values for the compressive strength, tensile strength, flexural strength and other properties of mortar shall be established through appropriate testing.
- (ii) The Young's modulus for mortar shall be established through appropriate test methods. As a rule, the stress-strain curve for mortar shall be determined by assuming a suitable mortar in accordance with the objectives of the study, based on test results.
- (iii) The material factors for mortar shall be established in accordance with Section 2.6 (2) in the Standard Specification (Design).

[Commentary]

(1) In the overlaying and jacketing construction method, special concretes are often used from the standpoint of bonding to existing concrete, suppression of cracking and so on. Accordingly, when the concrete demonstrates different dynamic properties from those of ordinary concrete, the characteristic values must be determined through appropriate testing. For example, within a suitable content range of 2% or less, steel fiber content will have almost no effect on the characteristic values for compressive strength and Young's modulus of steel fiber reinforced concrete, and these values may be considered to be the same as those for ordinary concrete. Nevertheless, to make the values for compressive toughness, flexural strength and toughness, tensile strength and shear strength greater than those of ordinary concrete with the same compressive strength, these values should be established through appropriate testing based on JCI-SF "Regulations Concerning Test Methods for Steel Fiber-Reinforced Concrete," JSCE-G 551 1983 (SFRC guidelines) "Test Methods for Compressive Strength and Compressive Toughness of Steel Fiber-Reinforced Concrete," JSCE-G 552 1983 (SFRC guidelines) "Test Methods for Flexural Strength and Flexural Toughness of Steel Fiber-Reinforced Concrete," JSCE-G 553 1983 (SFRC guidelines) "Test Methods for Shear Strength of Steel Fiber-Reinforced Concrete," and so on. In addition, regarding the flexural fatigue strength of steel fiber-reinforced concrete, it has been reported based on existing research that this value will be greater than that for ordinary concrete, but at the present time equations for calculating fatigue strength according to the type of steel fiber and the degree of fiber content have not yet been established. Accordingly, fatigue data should be accumulated through testing and an *S-N* curve derived to establish characteristic values for fatigue strength.

- (2) (i) Based on the present situation in which various types of mortar are used, tensile properties should be determined based on concrete tests equivalent to those indicated in JSCE-G 505-1995 "Test Methods for Compressive Strength of Mortar or Cement Paste Using Circular Column Test Pieces," JIS R 5201 "Physical testing methods for cement" and Section 3.2 in the Standard Specification (Design).
- (ii) The stress-strain curve for mortar will differ depending on the type of mortar and the mix, and in general the Young's modulus will change depending on the stress level. For this reason, a model in keeping with the performance to be verified should be established based on the results derived through JSCE-G 502-1988 "Test Method for Modulus of Static Elasticity for Concrete (draft)" and other appropriate tests.
- (iii) Since having the same material properties as concrete is a necessary condition for overlaying mortar, the material factor for mortar, like that for concrete, should be in accordance with Section 2.6 (2) in the Standard Specification (Design).

3.4.5 Steel

The characteristic values and design values for steel shall be in accordance with Section 3.3 in the Standard Specification (Design). For those materials not covered by the Standard Specification, the characteristic values and design values shall be determined through appropriate testing.

[Commentary]

Values for materials not covered by the Standard Specification must be determined through appropriate testing or the like.

Chapter 4 Load Action and Environmental action

Load action and environmental action shall be considered in accordance with the Standard Specification.

[Commentary]

In verifying the performance of existing structures and structures after retrofitting, consideration must be given to an appropriate combination of the load applied to the structure and the impact of the environment, in accordance with the performance being verified. When the changes in the performance of the structure over time during its service life are evaluated, the history of load action and environmental action on the structure must be considered. In general, permanent loads, accidental loads, variable load action and environmental action should be considered. When the performance of the structure at the time of verification is evaluated, appropriate values from among those for the assumed load action and effect of environment at that point in time should be selected in accordance with the performance to be verified. In these (draft) guidelines, the values are generally combined as shown in **Table C4.1.1** for the performance being verified.

Table C4.1.1 Combination of load action and environmental action

Performance	Actions that must be considered when evaluating changes in performance over time up to verification	Actions that should be considered at the time of verification
Safety	History of permanent load + accidental load + variable load + environmental action	Permanent load + primary variable load + secondary variable load
		Permanent load + accidental load + secondary variable load
		Permanent load + accidental load
		Permanent load + variable load
Serviceability		Permanent load + variable load
Restorability		Permanent load + accidental load + secondary variable load

Permanent loads, variable loads and accidental loads should be considered in accordance with the Standard Specification (Design). Of the accidental loads, seismic action should be considered in accordance with the Standard Specification (Seismic Design). Characteristic values for load and load factors should be determined in accordance with the Standard Specification (Design) (Seismic Design), based on the values shown in **Table C4.1.2**.

Table C4.1.2 Load characteristic values and load factors

Load characteristic values and load coefficients used for safety verification	Load characteristic values and load factors used for study of ultimate limit state
	Load characteristic values and load factors used for study of fatigue limit state
	Load characteristic values and load factors used for seismic performance 2 and 3 verification
Load characteristic values and load coefficients used for serviceability verification	Load characteristic values and load factors used for study of service limit state
Load characteristic values and load coefficients used for restorability verification	Load characteristic values and load factors used for seismic performance 1 and 2 verification

The effect of the environment on a structure includes ambient temperature, humidity, concentration of salts and other substances, the action of wetness and dryness, sunlight, ultraviolet light and so on. Environmental

action is applied continuously to the structure during its service life and is a primary cause of deterioration of, and changes in, the materials in the structure over time.

The environmental action that affects changes in performance over time is not uniform and depends on the type of structure, the site environment and other factors. In contrast to load action, general methods of expressing the size of the impact and fluctuations over time have not yet been established for many types of environmental action. Appropriate models of the history of the environmental action that match the construction method being used to predict changes over time must be created to consider these factors.

Environmental action relating to corrosion of the steel in the structure and freezing damage suffered to the concrete should be considered through reference to the Standard Specification (Design) and the Guidelines for Durability Design of Concrete Structures (draft). The Maintenance Guidelines (draft) cover methods for considering environmental action in accordance with a variety of structure deterioration phenomena.

CHAPTER 5 INSPECTION OF EXISTING STRUCTURES

5.1 General

- (1) An inspection shall be performed of existing structures for which retrofitting is being studied, in order to gather data needed to evaluate the various performance values of the structure at the time of retrofit design.
- (2) Inspections shall consist of two types: document checks and site inspections.
- (3) When inspecting structures, the study shall be conducted in accordance with the retrofitting method whose employment is being considered.

[Commentary]

(1) The need for retrofitting of an existing structure should be judged based on whether or not that structure fulfills performance requirements. Accordingly, the data needed to evaluate the performance of the existing structure should be gathered through inspections of that structure. When performing inspections, it should be kept in mind that quantitative data for calculating the dynamic performance of the structure is required to evaluate the various performance values. Particularly when deterioration or damage to the existing structure caused by salt damage, neutralization, freezing damage, alkali aggregate reaction, chemical concrete corrosion and fatigue has been confirmed through a primarily visual inspection, detailed reference materials regarding the deterioration of the structure can be obtained by performing a detailed inspection; see Chapter 4 "Inspections" in the Maintenance Guidelines (draft). However, deterioration from steel corrosion caused by salt damage and neutralization may have progressed even if no signs are apparent on the surface of the structure. Therefore, a detailed inspection must be performed if, considering the surrounding environment, the steel may be corroded.

For inspections in which retrofit is being considered to correct deterioration or damage caused by load action or environmental action, the inspection should consist of daily and periodic inspections up to the time at which the retrofitting study is conducted, and more detailed inspections based on the results of these daily and periodic inspections, in accordance with Chapter 4 "Inspections" in the Maintenance Guidelines (draft). When urgent situations must also be considered in the retrofitting of the structure, for example earthquakes, weathering or other natural damage or fire and collisions with motor vehicles, ships and so on, spot inspections should be conducted to gather as much data as quickly as possible. If retrofitting is being studied due to changes in the design load and as an earthquake proofing measure, the current status of the structure should be determined through prior inspections and more detailed site inspections performed later as needed.

(2) When studying retrofitting of structures, a document check should be performed first to obtain a general overview of the structure by organizing the design documents at the time the structure was built and, when necessary, the results of visual inspection and so on. Ambiguities or questions encountered in the document check should be cleared up through a detailed inspection at the site. This is done to enable as accurate an evaluation as possible of the performance of the structure at the time of the retrofitting study.

(3) Studies specific to the retrofitting method to be employed must be performed after the method has been selected. However, normally at the design documentation check and site survey stage, data needed to study the possibility of using the candidate retrofitting methods is gathered. Through these studies it is important to gather the data needed to determine whether or not each retrofitting method can be used and draft a construction plan.

5.2 Inspection Method

- (1) The document check shall be performed based on the design documents at the time of construction, the design documentation for repair and retrofitting work performed up until the time of the retrofitting study, and the results of visual inspection.
- (2) Site inspections shall be based on the results of the document check and shall cover the external appearance, surface, interior and surrounding environment of the structure.

[Commentary]

(1) In the document check, the date of design and construction, applicable standard, structural form, design conditions (material conditions, load conditions, etc.) foundation conditions and other matters should be identified. The document check also serves as a preliminary survey for a detailed inspection at the site. If the structure is one for whose performance would be difficult to evaluate from the results of daily inspections, periodic inspections and other primarily visual inspections, a plan for a detailed site inspection must be prepared. If no problems with the structure were discovered in the inspections conducted up to the time of the retrofitting study, the items in the detailed site inspection may be limited. From predictions of deterioration and damage in accordance with Chapter 3 "Predicting Deterioration" in the Maintenance Guidelines (draft), the possibility and degree of deterioration and damage caused by load action or environmental action on the structure in question can be predicted to some extent. If daily and periodic inspection records cannot be obtained, a visual inspection may be performed and the results added to a determination of the present status of the structure before conducting the detailed inspection at the site. If various types of monitoring are currently being performed for the structure, this data may also be used as reference. If repair and retrofitting work has already been performed for the structure, the relevant reference materials should be studied as well to determine the reason that retrofitting must again be considered. These procedures are necessary because they will aid in the selection of retrofitting materials and maintenance of the structure after retrofitting. **Table C5.2.1** shows the items for the document check in the case of retrofitting a bridge.

Table C5.2.1 Sample of document check items (bridge)

Type of Study	Study Item
Time of design / construction	Time of design / construction and age of structure
Applicable standard	Type of applicable standard
	Date enacted
Type of structure	Class
	Type of bridge
	Span length
	Bridge length
Type of structure	Lane width
Design conditions	Load conditions
	Material conditions (material strength, etc.)
	Section dimensions
	Steel reinforcements (diameter, quantity, placement, stress level, etc.)
Foundation conditions	Support conditions
	Geology and topography
Visual inspection records	Existence of, and location of, deterioration and damage
Other	Repair/retrofitting history
	Location of annexed structures and construction status

When detailed design documentation such as design documents and design calculations are available, it is possible to confirm the detailed specifications on the placement of reinforcing bars and the like, load action assumed during design and models of member characteristics. When detailed design documentation is not available, the ratio of reinforcement, load action during design and models of member characteristics can be deduced in many cases by determining standards of conformance to the shape and size of the structure.

(2) Even from the document check alone, it is possible to gather the data needed to evaluate the performance of the structure. However, since the design documentation may not match the current status of

the structure, performing an inspection at the site is recommended. In the site survey of the structure, the conformance to the design documentation, the actual environmental conditions at the structure, the degree of structural deterioration and damage (peeling, cracking, displacement etc.), the properties of the materials in the structure, and problems in implementing retrofitting work should be identified. Compared to visual inspections, detailed inspections at the site will require much more work, so the objectives of the inspection should be clarified and the inspection performed using an appropriate method for achieving these objectives. If no problems with the structure were discovered in evaluations during the daily and periodic inspections up to the point at the retrofitting study, the items required for the detailed inspection may be limited. For the items in detailed inspections of structures for which deterioration and damage has been discovered, and for spot inspections that are urgently required, refer to Chapter 4 "Inspections" in the Maintenance Guidelines (draft).

Table C5.2.2 shows sample survey items for site inspections covered by these (draft) guidelines, relating to surveys of structure safety, serviceability and restorability. Practical examples of survey items that are particularly necessary when evaluating load-carrying capacity are contained in Chapter 5 "Evaluation and Judgement" in the Maintenance Guidelines (draft).

The survey items generally included in site inspections are as follows:

1. Visual survey

From the external appearance of the structure, peeling, cracking status, rust fluid and free lime and the like can be surveyed. This corresponds to the daily and periodic inspections performed for ordinary structures. It is also conducted as needed before performing a detailed inspection. Primarily qualitative data is obtained through this type of survey; it would be most effective if this data could be reflected in performance evaluations of the structure.

Table C5.2.2 Sample survey items for site inspection

Type of Survey	Survey Item	
Conformance to design documents	Survey items in Table C5.1.1	
Survey of load and environmental conditions	Geographical conditions	Installation site / climatic conditions
	Traffic conditions	Amount of traffic, percentage of heavy vehicles, vehicle weight, road network
	Vibration / noise	
Survey of external appearance	Cracking status	Cracking location / width / density
	Defects	Concrete peeling, etc.
	Displacement / deformation	
	Rust fluid, free lime, discoloration, leakage of water	
Survey of interior	Performance of materials in structure	Concrete strength and modulus of elasticity / reinforcement strength and modulus of elasticity
	Reinforcing bar arrangement	Diameter / number / pitch / location
	Covering	
	Concrete deterioration	Interior cavities / depth of freezing damage
	Steel corrosion	Occurrence, percentage of steel section loss, natural displacement / polarization resistance / grout status
	Factors causing steel corrosion	Concrete neutralization depth / distribution of chlorides
Other	Foundation conditions	Support conditions / geology / ground water level
	Annexed structures	Location / construction status

2. Survey performed by means of chipping

This enables the concrete covering, neutralization depth, reinforcement corrosion etc. in particular to be surveyed.

3. Survey performed by means of test sampling

Test samples are taken from the structure and subjected to various types of analysis. This enables concrete strength, modulus of elasticity, neutralization depth, carbide ion content, reinforcement strength etc. to be surveyed.

4. Survey performed by means of nondestructive test

This is performed over a wide area in the structure and enables concrete internal defects (cavities, etc.), peeling, covering thickness, reinforcement positions, grout fill status etc. to be surveyed.

When highly reliable prediction methods can be used to predict the status of the materials in the structure, considering the history of load action and environmental action since the structure was built, these may be used in place of a portion of the inspections at the site.

If considerable damage or unexpected damage is discovered in site inspections, a detailed inspection including determination of the cause must be performed when necessary. Particularly with damaged structures, appropriate surveys for each objective must be implemented in sequence as needed: surveys with the objective of implementing emergency measures to prevent secondary disasters, surveys done to temporarily restore some of the functions, and surveys for permanent restoration.

(1)(2) In document checks and site inspections, surveys of items related to the retrofitting methods being considered are also performed. The inspection items relating to the external cable construction method, bonding and jacketing construction method and overlaying and jacketing construction method are described below.

External cable construction method

When studying the use of this method, it is necessary to check in the survey of geographical conditions to see whether or not there is enough space to place the external cables. In the external appearance survey, the placement of anchorage sections and deviators must be kept in mind and potential positions selected, and a survey of the status of cracking in the concrete surface at those locations and the presence of free lime and rust fluid, etc. must be conducted. In the interior survey, holes must be drilled in most cases to install the anchorage sections and deviators, so the arrangement of reinforcements must be surveyed without cutting the reinforcements and internal cables placed in the existing structure. The anchorage sections in particular are generally placed near the member edge where reinforcements and internal cables are grouped together, so the methods of taking x-rays and exploratory drilling must be used to check the difference between the placement status in drawings and the actual placement status. The strength of the concrete at the potential placement positions for the anchorage and deviators must also be surveyed.

Bonding and jacketing construction method

With this method, if the deterioration of the concrete surface is considerable, the bonding of the reinforcement and concrete cannot be confirmed and the retrofitted structure may not fulfill performance requirements. Depending on the status of damage of the bonding surface, measures performed may include removal of the embrittled portions of the concrete before bonding, filling of cracks, waterproofing measures, section repair or partial paving reconstruction. When anchors are used to fasten the reinforcing materials, the reinforcement positions must be checked to ensure that the anchors do not cut the reinforcement in the existing concrete structure. Accordingly, with the bonding and jacketing construction method, the strength of the surface layer of the concrete on the bonding surface, the status of dirt and cracking on the bonding surface, the presence of rust fluid, free lime or leakage of water, floating and peeling of the covering concrete and other factors relating to the status of the concrete surface and the actual placement locations of the reinforcements should also be surveyed.

Overlaying and jacketing construction method

For this method, fundamentally the same survey as for the bonding method must be performed. In addition, with the upper surface overlaying method, the following surveys are crucial:

1. In order to bond the existing and overlaying sections, the water-resistant layer must be removed completely, so a thorough check must be made to see whether or not there is any waterproofing.

2. Even if there is nothing wrong with the appearance of the paving, the levelness of the paving with the upper surface overlaying sections must be ensured, so the range of longitudinal correction before and after thickness addition must be examined.
3. The number of sections and additional vertical girders added to decks should be examined. If these differ from other bridges, the damage status of the deck at the time the vertical girders were added may have been different. Depending on the status of damage, it may be difficult to use the upper surface overlaying method.

Chapter 6 Performance Verification for Existing Structures

- (1) When retrofitting of existing structures is being studied, performance items specified as performance requirements shall be examined to verify whether or not the structure has the required performance at the time of the study.
- (2) Evaluations of the performance of existing structures at the time of the retrofitting study shall be based on load and environmental conditions, the performance of the materials in the structure, structural specifications, status of structure and the like obtained through inspections of the structure.
- (3) Performance shall be verified through selection of an appropriate performance evaluation method. Refer to **Table 6.1.1** and use the study methods for various limit states indicated in the Standard Specification (Design) and the verification methods for seismic performance indicated in the Standard Specification (Seismic Design) to calculate indices for verifying performance.

When characteristic values based on actual measurements have been determined through inspections of existing structures, safety factors for performance verifications of existing structures that are different from those in the Standard Specification may be established.

Table 6.1.1 Verification indices contained in the Standard Specification (Design) (Seismic Design)

Performance and Performance Item		Verification Indices Depicted in Existing "Standard Specification"	Corresponding Limit State, etc.
Safety	Safety with respect to rupture and collapse	Flexural load-carrying capacity of sections	Study of ultimate limit state
		Shear capacity of members	
		Torsional capacity of members	
		Various fatigue capacity values	Study of fatigue limit state
	Response displacement, ductility ratio and residual displacement of structure in the event of an earthquake	Verification of seismic performance 2 and 3	
Safety with respect to rigid stability	Resistance moment	Study of ultimate limit state	
Service-ability	Driving and walking comfort	Displacement / deformation, stress level of materials in structure, crack width	Study of serviceability limit state
	Vibration-proof performance		
	Soundproof performance		
	Appearance		
	Visual stability		
Restorability		Response displacement, restorability ductility ratio and residual displacement of structure in the event of an earthquake	Verification of seismic performance 2
		Stress level of materials in structure	Verification of seismic performance 1

[Commentary]

(1)(2) Performance verifications for existing structures for which retrofitting is being studied are conducted to confirm whether or not the performance requirements for that structure are being fulfilled. The values for load and environmental conditions, performance of the materials in the structure, structural specifications and status of structure used for these verifications should be actual values obtained through inspections.

(3) As a rule, performance should be verified by selecting, from among the usable performance evaluation technologies, the method that most closely matches the objective. In recent years, remarkable progress has been made in finite element analysis and other evaluation technologies that can evaluate various performance values for structures with wide-ranging applicability and high accuracy. The past achievements, reliability and scope of each method should be considered and the performance evaluation method selected at the

engineer's discretion. When the dynamic performance of structures covered in the Standard Specification has been depicted using the verification indices shown in **Table 6.1.1**, it is possible to perform verification using the various examination methods for limit state in the Standard Specification (Design) and the seismic performance verification methods in the Standard Specification (Seismic Design).

Since it is possible to determine the uncertainty and the effects of changes over time from the time the structure was designed up to the present using measurement data obtained through inspections of the existing structure, different safety factors from those in the Standard Specification may be determined for use in performance verifications for the existing structure. For example, when the characteristic values for concrete strength can be obtained from the existing structure through appropriate testing, the material factors specified in the Standard Specification which also consider the difference in material strength between the test specimens and the structure may be reduced, as noted in Section 3.2. Member factors and load factors may also be set differently from the Standard Specification when actual measurements of member size and load data have been obtained through inspections.

Chapter 7 Selection of Retrofitting method

In selecting the retrofitting method, the current status of the existing concrete structure as determined through inspection, the performance of the structure, the performance required of the structure after retrofitting, the conditions for retrofitting construction work, the ease of maintenance, economy and other factors shall be considered.

[Commentary]

At the stage of selecting the retrofitting method, the current status of the existing structure and its performance are known, and the performance required for the structure after retrofitting and the conditions for retrofitting work are given. Factors that should be considered in selecting the method include the effectiveness of the various retrofitting methods with respect to the required performance improvements, the viability of execution of the retrofitting work, the impact of the retrofitting work on the surrounding environment, the ease of maintenance after retrofitting, economy and other factors.

In these (draft) guidelines, practical examples of methods for verifying the performance of retrofitted structures using the external cable method, bonding and jacketing method and overlaying and jacketing method, methods that are often used today and for which technologies are being established, are shown based on existing technologies. In actual retrofitting, a variety of retrofitting technologies (primarily these methods) are generally used together. With the diversification of retrofitting objectives and technical progress, many new methods are expected to be proposed in the future as well.

Table C7.1.1 shows a variety of retrofitting methods, including the three methods covered in these (draft) guidelines, that are designed to improve performance by modifying the dynamic properties of structures. The table classifies these methods by the objective of retrofitting and identifies the members to which they are generally applied and the performance that brings about the retrofitting effect. A summary[4][6-12] of the various retrofitting methods in **Table C7.1.1**, listed by retrofitting objective, is provided below. Since the application of the three methods covered in detail in these (draft) guidelines (external cable method, bonding and jacketing method and overlaying and jacketing method) has most often been limited to beams, columns, slabs and so on, these methods are classified under item 1 "Retrofitting of concrete members."

1. Retrofitting of concrete members

- Continuous fiber reinforced plate bonding construction method:
Bonding continuous fiber reinforced plates to the surface of the existing structure to restore or improve load-carrying capacity
- Continuous fiber reinforced plate jacketing construction method:
Jacketing with continuous fiber reinforced plates around the periphery of the existing structure to restore or improve load-carrying capacity and deformation characteristics
- Prestressed concrete jacketing construction method:
Placing prestressing wires and prestressing stranded steel wires in place of lateral ties around the periphery of existing member sections and using mortar and concrete to bond them in order to reinforce the structure. To increase the restraining effect of the inner concrete, the prestressing steel is generally stressed during placement. This method is sometimes used together with the mortar spraying method and precast panel jacketing method.
- Prestressing introduction (internal cable) construction method:
Using internal cables for the existing concrete members to provide prestressing and restore or improve the load-carrying capacity of the members.
- Repaving method:
Replacing some or all of the existing concrete members with new members through the use of precast members or concreting on site to restore or improve load-carrying capacity.

2. Retrofitting as a structural body

- Beam (girder) addition method:

Adding beams between the main girders of the existing reinforced concrete deck to reduce the deck span and restore or improve the load-carrying capacity of the reinforced concrete deck.

- Seismic wall addition method:

Placing new reinforced concrete walls between existing reinforced concrete rigid-frame bridge piers and bonding them to form a continuous unit in order to restore or improve the load-carrying capacity as a structural body.

- Support point addition method:

Supporting the intermediate sections of the beams and other existing concrete members with new members to reduce the span of the members in order to restore or improve the load-carrying capacity as a structure.

- Seismic isolation method:

Using seismic isolation bearings and the like to reduce the seismic energy applied to the structure in order to improve its various performance values during an earthquake.

3. Foundation retrofitting

- Underground wall (beam) addition method:

Connecting the foundations with cast-in-site diaphragm walls and underground connecting beams to distribute stress and ensure the stability of the entire system.

- Pile/footing addition construction method:

When pile foundations are damaged or there is residual displacement, adding piles or footings to increase the load-carrying capacity of the foundation.

- Foundation improvement method:

Improving the ground around the foundation with cement improvement materials to improve the ground bearing capacity and horizontal foundation resistance. Also prevents excessive pore water pressure and liquefaction.

- Steel sheet-pile coffering construction method:

Placing sheet-piles around the periphery of the footings and bonding them to the footings to improve bearing capacity and horizontal resistance.

- Foundation compacting method:

When insufficient foundation bearing capacity is a concern due to scouring or the like, using concrete or the like to compact the ground around the foundation in order to restore bearing capacity.

- Ground anchor method:

When bridge abutments or the like move or tilt laterally as a result of an earthquake, etc., using ground anchors to stabilize the bridge abutments.

4. Bearing retrofitting and prevention of bridge collapse

- Bearing replacement method:

Replacing existing bearings with new ones to restore or improve bearing function and prevent bridge collapse.

- Bearing retrofitting method:

Reinforcing the existing bearings themselves to restore or improve bearing function and prevent bridge collapse.

- Shoe/seat retrofitting method:

Reinforcing or widening the ends of the existing bearings to maintain or restore bearing function and prevent collapse of the superstructure.

- Movement restriction equipment installation method:

Install new movement restriction equipment on existing members to prevent excessive movement of bearings and main girders and prevent bridge collapse.

- Main girder connection method:

Connecting the adjoining main girders in the bridge axial direction with one another to prevent excessive movement of main girders and prevent bridge collapse. Also used as a method of connecting bridge girders to reduce noise.

- Balance method:

Using prestressing steel or the like to add additional supports to the supports for existing Gerber hinge girders to prevent sinking of suspended beams and bridge collapse.

- Elasticity restraint method:

Using external cables to connect the existing superstructure and substructure and introducing suitable stressing force to restrict the movement of the superstructure and prevent bridge collapse.

5. Repair of cracks and missing sections

- Crack fill method:

Forcing low viscosity resin and ultra-fine cement into the cracks in existing concrete members to seal the cracks.

- Fill method:

Filling cracks, rock pockets, cavities, peeling and other small-scale missing sections in existing concrete members with resin and mortar to repair sections.

- Section repair method:

Removing deteriorated or damaged portions of existing concrete members and then restoring these members to their original sectional status using materials with excellent bonding to existing concrete.

6. Ensuring transit routes on bridge road surface

- Pavement repair method:

Repairing damaged pavement to ensure safety and driving comfort.

- Expansion joint repair method:

Repairing and replacing damaged expansion joints to ensure safety and driving comfort.

When selecting the retrofitting method, the structure to be retrofitted and the performance to be improved (in other words, the objective of retrofitting) are given. Accordingly, the various conditions should be considered and the ideal retrofitting method selected from the various retrofitting methods listed by retrofitting objective in 1 - 6 above.

For example, seismic retrofitting is generally used for column members and is performed in most cases to improve safety and restorability. In such cases, the primary objective is to increase shear capacity and flexural load-carrying capacity and improve ductility, so in most cases the jacketing method that can satisfy these requirements is used. If retrofitting of column and other members alone is not sufficient, or if an improvement in the performance of the entire bridge structure is desired, in some cases seismic isolation and other retrofitting as a structural body, foundation retrofitting, or various bearing retrofitting methods are combined with this method.

For the retrofitting of bridge decks, it is comparatively common to have as an objective not only improved safety but improved serviceability in terms of driving comfort, vibration resistance and the like. In such cases, the bonding method and overlaying method are often used as methods to control the cracking and deflection that results from flexural fatigue and punching shear fatigue and to reduce the stress level generated in the members; in some cases, the repaving method is also adopted. In cases where the retrofitting of deck members alone is not sufficient, the beam addition method, support point addition method and other retrofitting methods as a structural body are sometimes adopted.

Table S7.1.1 (a) Relationship between performance verification indices and retrofitting methods

Retrofitting Objective	Measure	Specific Construction Method Name *1	Member *2										
			All	Beam	Column	Slab	Wall *3	Bearing	Pile	Foundation	Other		
Concrete member retrofitting	Bonding	Steel plate bonding method (bonding method)		●	○	●	○						
		Continuous fiber sheet bonding method (bonding method)		●	○	●	○						
		Continuous fiber retrofitted plate bonding method (bonding method)		○	○	○	○						
Concrete member retrofitting	Jacketing	Steel plate jacketing method (jacketing method)		○	○	○	○						
		Continuous fiber sheet jacketing method (jacketing method)		●	○	●	○						
		Continuous fiber retrofitted plate jacketing method (jacketing method)		○	○	○	○						
Concrete member retrofitting	Introduction of prestressing	Continuous fiber retrofitted plate jacketing method (jacketing method)		○	○	○	○						
		Retrofitted concrete jacketing method (jacketing method)		●	○	●	○						
		Precast concrete jacketing method (jacketing method)		●	○	●	○						
		Mortar spray method (jacketing method)		○	○	○	○						
		Precast panel jacketing method (jacketing method)		○	○	○	○						
		External cable method (external cable method)		○	○	○	○						
		Prestressing introduction (internal cable) method (method)		○	○	○	○						
		Upper surface overlaying method (overlaying method)		○	○	○	○						
		Lower surface overlaying method (overlaying method)		○	○	○	○						
		Lower surface spray method (overlaying method)		○	○	○	○						
Retrofitting as a structural body	Member replacement	Replacing method		○	○	○	○						
		Beam (girder) addition method		●	○	●	○						
		Seismic wall addition method		●	○	●	○						
		Support point addition method		●	○	●	○						
		Seismic isolation method		●	○	●	○						
		Underground wall (beam) addition method		○	○	○	○						
		Pier (column) addition method		○	○	○	○						
		Foundation improvement method		○	○	○	○						
		Steel sheet-pile coffering method		○	○	○	○						
		Foundation compaction method		○	○	○	○						
Foundation retrofitting	Improvement of foundation	Ground anchors		○	○	○	○						
		Replacement of bearings (including seismic substructure)		●	○	●	○						
		Replacement of bearings themselves		○	○	○	○						
		Retrofitting of bearings		○	○	○	○						
		Retrofitting of bearings and bridge seats		○	○	○	○						
		Movement restrictions		○	○	○	○						
		Shift to continuous girders		○	○	○	○						
		Garber girders		○	○	○	○						
		Elasticity restrain method		○	○	○	○						
		Crack fill method		○	○	○	○						
Repair of cracks and missing sections	Repair	Fill method		○	○	○	○						
		Section repair method		○	○	○	○						
		Pavement repair method		○	○	○	○						
		Expansion joint repair method		○	○	○	○						
Grouting repair holes on bridge deck surface	Grouting	Grouting repair method		○	○	○	○						
		Expansion joint repair method		○	○	○	○						

Notes *1 Pavement repair method names indicate correspondence with method names noted in these draft guidelines *2 ●: Used comparatively often ○: Use is thought to be possible *3 ●: Through to be very effective ○: Somewhat effective but effect is thought to be comparatively minor (indirect) *4

Table S7.1.1 (b) Relationship between performance verification indices and retrofitting methods

Retrofitting Objective	Measure	Specific Construction Method Name ^{*1}	Performance Verification Index ^{*2}												
			Safety					Serviceability							
			Axial force	Bending	Shear	Torsion	Fatigue	Rigid body stability	Ductility	Crack width/deflection/displacement	Other	Restorability			
Concrete member retrofitting	Bending	Steel plate bonding method (bonding method)	●	●	●	●	●	●	●	●	○	●	○	○	○
		Continuous fiber sheet bonding method (bonding method)	○	●	●	●	●	●	●	●	●	○	●	○	○
		Continuous fiber reinforced plate bonding method	○	●	●	●	●	●	●	●	●	○	●	○	○
		Steel plate jacking method (jacking method)	●	●	●	●	●	●	●	●	●	○	●	○	○
		Continuous fiber sheet jacking method (jacking method)	●	●	●	●	●	●	●	●	●	○	●	○	○
	Jacking	Continuous fiber retrofitted plate jacking method	●	●	●	●	●	●	●	●	○	●	○	○	○
		Retrofitted concrete jacking method (jacking method)	●	●	●	●	●	●	●	●	○	●	○	○	○
		Precast concrete jacking method	●	●	●	●	●	●	●	●	○	●	○	○	○
		Monorail spray method (jacking method)	●	●	●	●	●	●	●	●	○	●	○	○	○
		Precast panel jacking method (jacking method)	●	●	●	●	●	●	●	●	○	●	○	○	○
Introduction of prestressing	External cable method (external cable method)	○	○	○	○	○	○	○	○	○	○	○	○	○	
	Prestressing introduction (internal cable) method	○	○	○	○	○	○	○	○	○	○	○	○	○	
	Upper surface overlaying method (overlaying method)	○	●	●	●	●	●	●	●	○	○	○	○	○	
	Lower surface overlaying method (overlaying method)	○	●	○	○	○	○	○	○	○	○	○	○	○	
	Lower surface spray method (overlaying method)	○	●	○	○	○	○	○	○	○	○	○	○	○	
Member replacement	Repairing method	●	●	●	●	●	●	●	●	○	○	○	○	○	
	Beam (girder) addition method	●	●	●	●	●	●	●	●	○	○	○	○	○	
	Seismic wall addition method	●	●	●	●	●	●	●	●	○	○	○	○	○	
	Support point addition method	●	●	●	●	●	●	●	●	○	○	○	○	○	
	Self-healing method	●	●	●	●	●	●	●	●	○	○	○	○	○	
Foundation retrofitting	Addition of walls and beams	○	○	○	○	○	○	○	○	○	○	○	○	○	
	Pile (footing) addition method	○	○	○	○	○	○	○	○	○	○	○	○	○	
	Foundation improvement method	○	○	○	○	○	○	○	○	○	○	○	○	○	
	Steel sheet-pile coffering method	○	○	○	○	○	○	○	○	○	○	○	○	○	
	Foundation compaction method (ground anchor method)	○	○	○	○	○	○	○	○	○	○	○	○	○	
Bearing retrofitting and prevention of bridge collapse	Bearing replacement method	○	○	○	○	○	○	○	○	○	○	○	○	○	
	Bearing retrofitting method	○	○	○	○	○	○	○	○	○	○	○	○	○	
	Shoelace retrofitting method	○	○	○	○	○	○	○	○	○	○	○	○	○	
	Movement restriction equipment installation method	○	○	○	○	○	○	○	○	○	○	○	○	○	
	Main girder connection method	○	○	○	○	○	○	○	○	○	○	○	○	○	
Repair of cracks and infilling sections	Balancing method	○	○	○	○	○	○	○	○	○	○	○	○	○	
	Elasticity restraint method	○	○	○	○	○	○	○	○	○	○	○	○	○	
	Crack fill method	○	○	○	○	○	○	○	○	○	○	○	○	○	
	Fill method	○	○	○	○	○	○	○	○	○	○	○	○	○	
	Section repair method	○	○	○	○	○	○	○	○	○	○	○	○	○	
Ensuring travel routes on bridge road surface	Pavement/repair method	○	○	○	○	○	○	○	○	○	○	○	○	○	
	Expansion joint repair method	○	○	○	○	○	○	○	○	○	○	○	○	○	

Notes: ^{*1} Parentheses after method names indicate correspondence with method names noted in these (draft) guidelines. ^{*2} ●: Used comparatively often. ○: Use is thought to be possible. ^{*3} Including wall-type bridge piers. ^{*4} Thought to be very effective. ^{*5} Effective primarily for punching shear.

CHAPTER 8 CONSIDERATIONS IN RETROFITTING DESIGN AND CONSTRUCTION

When conducting retrofitting with the external cable method, the bonding and jacketing method and the overlaying and jacketing method, design and construction must ensure that the following requirements are met:

- (1) Ensure bonding of existing members and retrofitted members
- (2) Prevent deterioration of the retrofitted members resulting from load action and environmental action during service life

[Commentary]

(1) With the external cable method, the bonding and jacketing method, the overlaying and jacketing method and many of the other retrofitting methods used today, retrofitting will be suitably effective when bonding of the existing members and retrofitted members has been ensured. The performance evaluation methods for retrofitted structures covered in Chapter 9 of these (draft) guidelines are designed to evaluate performance with bonding having been secured. Accordingly, when using these three methods for retrofitting, it is crucial to conduct retrofitting design and construction so the existing members and retrofitted members will bond together.

(2) There are also currently no technologies established for general prediction of changes over time in retrofitted members due to the effect of load or environmental action during the service life of the structure. Accordingly, thorough measures to prevent deterioration are generally conducted at the retrofitting stage to ensure that the deterioration of retrofitted members is extremely slight, or so no deterioration will occur within the range that can be predicted with existing technologies.

(1)(2) The Retrofitting Manuals accompanying these (draft) guidelines contain considerations for design and construction for the external cable method, the bonding and jacketing method and the overlaying and jacketing method to enable requirements (1) and (2) above to be fulfilled, based on existing technologies. If, as a result of technical progress, methods are established that enable the performance of the structure after retrofitting to be evaluated with suitable accuracy, regardless of the method used to design and construct retrofitted members, the matters in these Retrofitting Manuals need not be strictly observed.

Chapter 9 Performance Verification for Retrofitted structures

9.1 General

The safety, serviceability and restorability of retrofitted structures using the external cable method, bonding and jacketing method and overlaying and jacketing method shall be verified using the methods described in this chapter.

[Commentary]

The performance of retrofitted structures with the selected retrofitting method and construction method must be evaluated using appropriate methods and verified to ensure that performance requirements are fulfilled. The performance of retrofitted structures is accomplished by a combination of the retrofitting members and the members in the existing structure. Accordingly, in the evaluation, not only the performance of the retrofitting members but the cracking and other damage, deformation, and stress in the existing structure must be suitably considered when necessary. This chapter covers the methods used to evaluate the safety, serviceability and restorability of retrofitted structures using the external cable method, bonding and jacketing method and overlaying and jacketing method, with existing technologies. If, due to technological progress, it becomes possible to use even more appropriate performance evaluation methods of confirmed reliability, the methods described here need not necessarily be observed.

9.2 Verification of Safety

9.2.1 Flexural and Axial Load-Carrying Capacity

The safety of the structure shall be verified by confirming that the flexural and axial load-carrying capacity of retrofitted members is greater than the flexural and axial force acting on the structure.

- (1) External cable method
 - (i) The flexural and axial load-carrying capacity of retrofitted member sections or member unit widths shall be calculated in accordance with Section 6.2.1 (2) of the Standard Specification (Design) and the following assumptions.
 - 1. The increase and decrease in fiber strain in the external cables accompanying the increase or decrease of load action can be expressed by the average strain derived from the changes in strain at the external cable center of gravity along the entire external cable length accompanying deformation in the concrete member.
 - 2. The effective depth of the external cable in the area not supported by deviators will change along with deformation of the concrete member.
 - (ii) The flexural load-carrying capacity of member sections or member unit widths where the effective depth of the external cable is thought to experience relatively little change shall be determined by deriving the tensile stress level of the external cable at the ultimate bending point using **Equation 9.2.1** and calculating based on the assumptions in Section 6.2.1 (2) of the Standard Specification (Design).

$$f_{ps} = f_{pe} + Df_{ps} \dots\dots\dots(\text{Equation 9.2.1})$$

where:

- f_{ps} :Ultimate external cable tensile stress level
- f_{pe} :Tensile stress level due to prestressing force
- Df_{ps} :Ultimate increase in external cable tensile stress level

- (2) Bonding and jacketing method
 - (i) The axial load-carrying capacity of members retrofitted by jacketing with reinforcing materials shall be determined by methods that give suitable consideration to the effect of the retrofitting members.
 - (ii) When calculating the load-carrying capacity for members retrofitted by attaching reinforcing materials to the surface to which tensile stress is applied, when these members are subjected to bending moment

or bending moment and axial force, peeling shall be considered. If it can be confirmed using appropriate methods that peeling will not occur, the load-carrying capacity may be calculated with no occurrence of peeling.

- (iii) If no peeling of the reinforcing materials occurs, the load-carrying capacity for sections or unit widths of members retrofitted by attaching reinforcing materials to the surface to which tensile stress is applied, when these members are subjected to bending moment or bending moment and axial force, shall be calculated in accordance with Section 6.2.1 (2) of the Standard Specification (Design) and the assumptions below, based on the force equilibrium conditions and applicable strain conditions for each type of bending failure mode.
 1. The fiber strain for the reinforcing materials is proportional to the distance from the neutral axis of the section.
 2. The stress-strain curve for the reinforcing materials is in accordance with 3.4.

(3) Overlaying and jacketing method

Calculation of flexural and axial load-carrying capacity shall be in accordance with Section 6.2 of the Standard Specification (Design).

[Commentary]

- (1) (i) Assumptions that a plane remains after deformation cannot be applied to prestressing materials that are not attached to the concrete, such as external cables. Also, since external cables contact concrete members only at the anchorage sections and deviators, an increase in the deformation of the concrete members results in a relatively great change in the effective depth of the external cable in the areas where it is not supported by deviators, and in general the flexural load-carrying capacity tends to be lower than if the effective depth did not change. Here the effect of these factors has been considered and it was decided to use as a basis the calculation of flexural load-carrying capacity of members or member sections retrofitted with external cables.

One specific method of calculating flexural load-carrying capacity is non-linear analysis that takes into consideration the non-linearity and geometric non-linearity of the materials. In recent years, research into the flexural nature of external cable structures has been underway in Japan as well, and technologies are being established for using non-linear analysis to suitably evaluate the above effects and evaluate bending failure capacity with comparative accuracy. However, when calculating the bending failure capacity of members retrofitted with external cables, it would be best to use non-linear analysis which is capable of calculating flexural load-carrying capacity as a structural system.

- (ii) When the placement spacing of deviators is comparatively small, as compared to the span length, and deviators are placed near the locations at which maximum and minimum bending moment are applied, etc., the effective depth of the external cables can be seen as experiencing relatively little change even if deformation of the concrete members occurs. In such cases, non-linear analysis is thought to be an advanced method as judged from the general level of technology, so it was decided that **Equation 9.2.1** should be used to calculate the tensile stress of the external cables during failure and to calculate the flexural load-carrying capacity in accordance with conventional bending theory.

The increase in the tensile stress level of external cables at failure is affected by many factors, including the type of external cable, span length and deviator placement status, configuration of deviators, ratio of span and effective depth, and cross-sectional area ratio of internal and external cables. Accordingly, in general the value or the method used to set that value must be specified after the structure to be retrofitted or the structural conditions and other applicable ranges have been identified. However, almost no specific methods have been proposed, and at present the method is to consult standards and research reports relating to external cable configurations to determine whether, to be safe, an increase in stress level should be factored in, and then estimate the value.

According to previous reports[13], when using external cable construction with prestressing steel to build new concrete box girder bridges with a standard span (40 - 60m) and girder height of 2 meters or more, an increase in stress level of about 200 N/mm² can be expected even if some leeway is provided. However, it has been pointed out that, when the ratio between girder height and span is 35 or greater, and when the ratio between the placement spacing for deviators and the span is 2/3 or more, caution is

required, as in some cases the increase in stress level will be less than 200 N/mm². When using this method to calculate the bending failure capacity, it is necessary to consider the bending failure mode of the retrofitted structure. With structures that use both internal and external cables that, like those retrofitted with external cables, have a comparatively large number of internal cables and amount of tension reinforcement compared to the external cables, after yielding of the internal cables, compressive failure of the concrete leading to member failure may occur almost before the stress level of the external cables has increased at all, so this must be considered as well. When a member reaches failure due to flexural compressive failure of the concrete, the distribution of concrete compressive stress levels may be assumed to be the distribution of rectangular compressive stress levels (equivalent stress blocks) in **Figure 6.2.1** in the Standard Specification (Design).

When continuous fiber prestressing materials are used for external cables and one of the continuous fiber prestressing materials reaches ultimate strain and fails, resulting in fiber breakage type bending failure, the result of the compressive force and tensile force at that point must be accurately evaluated to calculate the flexural load-carrying capacity of the retrofitting members. In situations such as when continuous fiber prestressing materials have been placed in many levels, fiber breakage type bending failure will occur when the outermost continuous fiber prestressing materials reach ultimate strain, so in general the flexural load-carrying capacity must be evaluated using the strain of the outermost continuous fiber prestressing materials.

- (2) (i) According to past testing, when jacketing with steel plates has been conducted, the axial compressive load-carrying capacity and deformability are increased. When continuous fiber sheets have been used for jacketing, in general there is not much increase in the axial compressive load-carrying capacity while the deformability is greatly increased. It was decided that, when an increase in load-carrying capacity has been confirmed through testing or the like, the effect should be considered using suitable methods.
- (ii) (iii) When no peeling of the reinforcing materials occurs, the deformation and load-carrying capacity of the retrofitted members can be determined based on conventional flexural theory for reinforced concrete beams. Conventional bending failure modes include (1) reinforcement yielding - breakage of the continuous fiber reinforcing materials (2) reinforcement yielding - concrete collapse and (3) concrete collapse, so appropriate evaluation is needed. In addition to the conventional bending failure modes, peeling failure is also possible, such as that due to anchorage section failure, or due to peeling at the cracking position that results from tensile force, or due to peeling caused by displacement between the intersections of shear cracking and reinforcing materials. In general, this type of peeling failure should be prevented. However, if the flexural load-carrying capacity in the ultimate peeling state can be appropriately calculated, in some cases no special measures to prevent peeling failure need be taken. To accurately evaluate the behavior of members in the ultimate peeling state, it is necessary to use calculation methods that consider the effect of the occurrence and progress of peeling and numerical analysis methods such as finite element analysis.

Research is currently underway regarding criteria for peeling. However, for the steel plate bonding and continuous fiber sheet bonding methods, the methods shown below based on the anchorage length have been proposed. With the steel plate bonding method, **Equation C9.2.1** can be used to calculate the anchorage length for which steel plate peeling occurs when the steel plate stress level reaches the yield point in the section with the greatest bending moment[14]. In this case, the anchorage length is chosen so the bending moment is a lower value than the section with the greatest bending moment.

$$l_p = a \left\{ 1 - \left(\frac{h_p - x}{h_p x_0} \right) \left(\frac{K_2}{K_1} \right) \left(\frac{I_0}{I} \right) \left(\frac{f_t}{s_{py}} \right) \right\} + K_2 t_p \dots\dots\dots \text{(Equation C9.2.1)}$$

where:

- l_p : Anchorage length at which the steel plate peels at the point where it reaches the yield point (mm)
- a : Shear span (mm)
- h_p : Distance from beam compressive edge to steel plate center of gravity

- x_0 : Neutral axis position in steel plate bonding section that is effective throughout the entire section (mm)
- I_0 : Moment of inertia of cross-section for neutral axis position in steel plate bonding section that is effective throughout the entire section (mm⁴)
- x : Neutral axis position in steel plate bonding section with tension side ignored (mm)
- I : Moment of inertia of cross-section for neutral axis position in steel plate bonding section with tension side ignored (mm⁴)
- f_t : Tensile strength of concrete (N/mm²)
- s_{py} : Yield point of steel plate (N/mm²)
- t_p : Plate thickness (mm)
- K_1, K_2 : Coefficients that consider whether or not there is any cracking in the edge of the steel plate (see **Table C9.2.1**)

Table C9.2.1 Coefficients K_1 and K_2

No cracking at steel plate edge			Cracking at steel plate edge		
Plate thickness (mm)	K_1	K_2	Plate thickness (mm)	K_1	K_2
4.5	1.59	21.5	4.5	0.91	25.4
6.0	1.56	16.9	6.0	0.90	20.4
9.0	1.52	12.1	9.0	0.88	15.2
12.0	1.51	9.3	12.0	0.85	12.1

Equation C9.2.1 was arrived at analytically based on test results in which peeling of the steel plate anchored to the middle of the tension edge of the concrete member occurred at the edge of the steel plate. The equation was validated using several reinforced concrete beam test specimens. Coefficients K_1 and K_2 in the equation were included to consider the effect of whether or not there was any cracking in the edge of the steel plate; as shown in **Table C9.2.1**, these values will vary depending on the thickness of the steel plate. In determining the anchorage length, the value for l_p derived through **Equation C9.2.1** and the length necessary for strengthening should be compared and the longer value made the basic anchorage length. Next, a length equivalent to the effective depth of the member with consideration for moment shift should be added to the basic anchorage length to derive the total anchorage length of the steel plate.

With the continuous fiber sheet bonding method, in general an anchorage that will ensure that peeling does not occur with respect to the design load should be derived using **Equation C9.2.2**.

$$l_{afs} > \frac{f_{afsd} \cdot n \cdot t_{afs}}{t_{afs}} \dots\dots\dots \text{(Equation C9.2.2)}$$

where:

- l_{afs} : Anchorage length that will ensure that peeling does not occur with respect to the design load (mm)
- f_{afsd} : Tensile stress level applied to continuous fiber sheet during design load (N/mm²)
- n_{afs} : Number of ply of continuous fiber sheet
- t_{afs} : Thickness of one ply of continuous fiber sheet (mm)
- t_{afs} : Bonding strength of continuous fiber sheet to concrete (determined through consideration of the type and number of ply of the continuous fiber sheet, the strength of the concrete surface, member dimensions and other factors) (N/mm²)

Equation C9.2.1 is a simple method for verifying the occurrence of peeling in members retrofitted with continuous fiber sheets. With this method, the value derived by multiplying the bonding strength by the bond area (bond failure load) can be compared with the tensile force applied to the retrofitted member during flexural resistance, derived based on the assumptions in 9.2.1 (2). The bonding strength will differ depending on the test method, member dimensions, attachment length of continuous fiber sheets, type of continuous fiber sheet and number of ply, concrete surface strength and surface treatment method, and other factors. Accordingly, when using this simple verification method, these factors must be considered to ensure that a reliable value for bonding strength is used. Moreover, this method is not meant to preclude the use of other methods capable of more accurately determining the occurrence of peeling.

(3) Calculations of the flexural load-carrying capacity after flexural retrofitting are based on the premise that the existing members and overlaying concrete behave as a single unit so no peeling occurs. Accordingly, when the overlaying section subjected to bending is in the tension zone, the concrete on the tension side is ignored. In bridge decks with positive moment in which the overlaying section is located in the compression area, the concrete in the overlaying sections and existing sections will have different values for strength and modulus of elasticity, so the characteristic values for overlaying reinforcing materials derived in accordance with Section 3.4.4 should be used to calculate the flexural load-carrying capacity. Nevertheless, in general, the strength of the concrete used in overlaying sections is greater than that of existing sections, so when calculating the flexural load-carrying capacity in such cases, the stress-strain relationship for the existing sections may simply be used for the overlaying sections as well.

9.2.2 Shear Capacity of Bar Members

The safety of the structure shall be verified by confirming that the shear capacity of retrofitted bar members is greater than the shear force applied.

(1) External cable method

The shear capacity of retrofitted bar members V_{ud} shall be derived using **Equation 6.3.2** in the Standard Specification (Design), with consideration given to the reinforcing effect of the external cables, based on the methods below.

1. The shear capacity of bar members that do not use shear reinforcing steel V_{cd} shall be derived using **Equation 6.3.3** in the Standard Specification (Design), with consideration given to the increase in axial compressive force due to the external cables.
2. The components V_{ped} of the effective tensile force of the axial stressing members that are parallel to the shear capacity shall be calculated by adding the components V_{aped} of the effective tensile force of external cables derived with **Equation 9.2.2** that are parallel to shear capacity to those for the internal cables.

$$V_{aped} = P_{aed} \cdot \sin a_{ap} \dots\dots\dots(\text{Equation 9.2.2})$$

where:

P_{aed} : Effective tensile force of external cables

a_{ap} : Angle formed by external cable and member axis

(2) Bonding and jacketing method

- (i) The shear capacity of bar members V_{ud} shall be derived in accordance with 6.3.3 in the Standard Specification (Design), with consideration given to the effect on the shear capacity of the reinforcing materials derived with **Equation 9.2.3**.

$$V_{awd} = b_{aw} [A_{aw} f_{awu} (\sin a_{aw} + \cos a_{aw}) / b_{aw}] z / g_b \dots \dots \dots \text{(Equation 9.2.3)}$$

where:,

- V_{awd} : Shear capacity supported by reinforcing materials
- b_{aw} : Coefficient indicating stress distribution of reinforcing materials in truss when shear force is applied. In general, this is 1.0 for steel plates and a value less than 1.0 for continuous fiber sheets.
- A_{aw} : Cross-sectional area of reinforcing materials per unit width when placed at angle a_{aw}
- b_{aw} : Unit width of reinforcing materials
- f_{awu} : Design yield strength (for steel plate); design tensile strength (for continuous fiber sheet)
- a_{aw} : Angle formed by reinforcing materials and member axis
- z : Distance from position at which force resulting from compressive stress is applied to the tension steel center of gravity; generally set to $d/1.15$
- g_b : Generally set to 1.15

- (ii) Calculations of the shear capacity when reinforcing materials are attached to the side of the bar members shall be derived with methods that give appropriate consideration to the effect of the reinforcing materials.

(3) Overlaying and jacketing method

- (i) The shear capacity for retrofitted bar members V_{ud} shall be determined with **Equation 9.2.4** in accordance with 6.3.3 in the Standard Specification (Design), with consideration given to the effect of the overlaying on shear capacity.

$$V_{ud} = V_{cd} + V_{sd} + V_{ped} + V_{asd} \dots \dots \dots \text{(Equation 9.2.4)}$$

where:,

- V_{cd} : Shear capacity of bar members that do not use shear reinforcing materials utilizing the width and effective depth of the web including the concrete jacketed section
- V_{sd} : Shear capacity supported by shear reinforcement in existing members
- V_{ped} : Components of axial stressing members with effective tensile force parallel to shear capacity
- V_{asd} : Shear capacity supported by added shear reinforcing steel

- (ii) The tangential compressive capacity V_{wcd} with respect to the shear capacity of the web concrete shall be determined in accordance with **Equation 6.3.7** in the Standard Specification (Design), using the width and effective depth of the web section including the concrete jacketed section.

[Commentary]

(1) The shear capacity of retrofitted bar members V_{ud} is the sum of the concrete share of the force V_{cd} , the shear reinforcing steel share of the force V_{sd} , the component force in the shear direction V_{ped} of the effective tensile force for the internal cables, and the component force in the shear direction V_{aped} of the effective tensile force for the external cables. This value should be derived with **Equation 6.3.2** in the Standard Specification (Design). In practical terms, as shown in each of the methods (1 and 2), the value for b_n when calculating the concrete share of the force V_{cd} , and the value for component V_{aped} of the effective tensile force of the external cables that is parallel to the shear force, should be used to consider the effect on shear capacity of retrofitting of the external cables.

However, when considering the addition of axial compressive force due to the external cables in calculating b_n , for the sake of simplicity M_0 may be calculated with the entire concrete section considered to be effective,

even for sections in which cracking has developed. When calculating the shear direction component V_{ped} for the effective tensile force of the internal cables, consideration must be given to the fact that the effective tensile force of the internal cable will be decreased as a result of retrofitting with external cables. Also, as shown in **Figure C9.2.1**, in cases such as when verification indices are calculated through structural analysis utilizing the converted external force loading method applied to structural models, in which the force resulting from action of external cables on the anchorage and deflection positions is a concentrated load or distributed load, no further consideration should be given to the share of the force V_{aped} from the external cables if the shear force produced by the tension of the external cables has already been considered using some method.

When the increase in external cable tension at the time of shear failure can be evaluated using appropriate methods, the additional tension DP_{aed} can be added to the effective tensile force of the external cables P_{aed} to derive the share of the force V_{aped} from the external cables.

(2) (i) It was decided to express the design shear capacity when bar members are jacketed with reinforcing materials by simply adding the share from the reinforcing materials V_{awd} to the shear capacity of the existing members (the sum of the shares of the concrete and the shear reinforcing materials). According to past test results, the shear capacity supported by continuous fiber sheets when members were jacketed with continuous fiber sheets is lower than the value calculated with truss theory using the tensile strength of the continuous fiber sheets. Reasons for this include the fact that continuous fiber sheets are an elastic body that does not have a plastic range and therefore do not redistribute stress as does steel, so the stress distribution in the truss will not be uniform, and also the fact that, depending on the elongation capacity of the continuous fibers and the quantity used for jacketing, the failure mode is shear compressive failure of the concrete that does not accompany breakage of the continuous fibers. Also, the breakage strain of continuous fiber sheets is greater than the yield strain of conventional reinforcements, so in the event of shear failure it is also possible that excessive diagonal cracking widths, or engagement of the aggregate on the cracking surface, or a drop in the shear force transmitted by the dowel action of the axial reinforcement, may occur, or that local deformation and accumulated stress at the crack location may cause the continuous fiber sheet to break at a lower stress than the uniaxial tensile strength. In these (draft) guidelines, for convenience of design, it was decided to consider the effect of these factors using the coefficient b_{aw} in **Equation 9.2.3**. In other words, the value calculated in accordance with truss theory using tensile strength should be reduced using a coefficient b_{aw} less than 1.0. Accordingly, when using **Equation 9.2.3** to calculate the shear capacity, the coefficient b_{aw} must be set to an appropriate value for the type and quantity of continuous fibers used for jacketing, the member dimensions and so on, based on test results and the like.

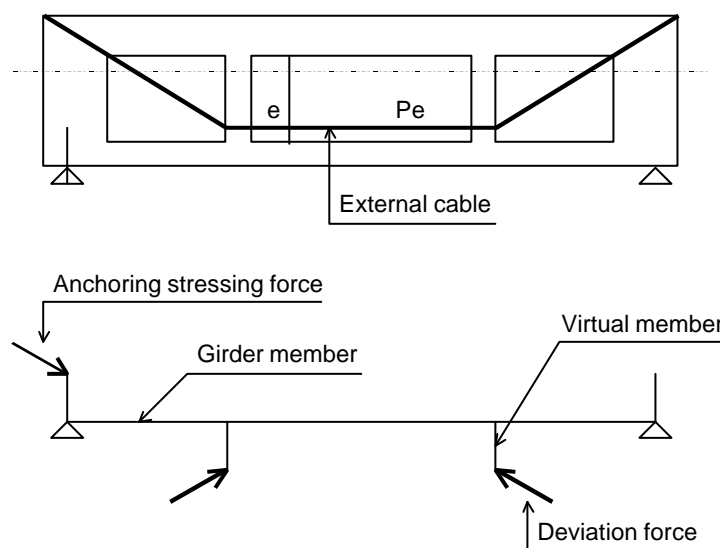

Figure C9.2.1 Structural analysis model using the converted external force loading method

When continuous fiber sheets are used as a reinforcing material, depending on the surface treatment method, the bonding strength of the reinforcing materials and the existing members may not be adequate. In general, when bonding strength does not act, the accumulation of stress at the crack position is less than when a bond exists, making it difficult for the continuous fiber sheet to break. However, this differs in some ways, such as the fact that the shear force supported by the continuous fiber sheet is reduced. When designing without the expectation of bonding strength, an appropriate method that considers these differences must be used to derive the shear capacity.

- (ii) When reinforcing girders, in many cases it is not possible to jacket with reinforcing materials. Accordingly, the shear retrofitting method in such cases is to attach the reinforcing materials to the side, or use them to jacket in a U-shape. In such cases, as the ultimate load-carrying capacity is generally determined by the peeling of the reinforcing materials, a great shear reinforcing effect cannot be expected. Accordingly, the reinforcing materials should be anchored mechanically to the top and bottom edges of the girder web, etc. According to previous tests, using anchors to anchor the continuous fiber sheets at the top of the web when jacketing in a U-shape increases the shear capacity. Nevertheless, no methods have been established for rational evaluation of shear capacity, including design methods for anchor anchorages, and when considering this type of shear reinforcement, testing and other appropriate methods must be used to confirm the capacity.
- (3) (i) It was decided to represent the shear capacity of retrofitted bar members as the sum of the concrete share V_{cd} including the concrete jacketed sections, the share of the shear reinforcement in the existing members V_{sd} , and the share of the shear reinforcement in the jacketed sections V_{asd} . Here, to the extent that the amount of reinforcement is small, the shear reinforcement in the jacketed sections is thought to have the same effect as the shear reinforcement in the existing members. For this reason, it was thought that truss theory with the angle of the diagonal compressive member set to 45° could basically be applied to the share of shear reinforcement in the jacketed sections V_{sd} as well. In addition, when axial reinforcement is added to the tension side during jacketing, this can be thought of as tension steel when calculating the value for V_{cd} .

9.2.3 Punching Shear Capacity of Surface Members

The safety of the structure shall be verified by confirming that the punching shear capacity of retrofitted surface members is greater than the punching shear force that is applied.

When the overlaying and jacketing method is used and the load surface is separated from the free end of the member or the opening and the eccentricity of the load is small, the punching shear capacity must be calculated with appropriate consideration given to the effect of the reinforcing material.

[Commentary]

The upper surface overlaying method and lower surface overlaying method are used primarily for retrofit of the reinforced concrete decks of highway bridges. A variety of proposals have been made for the punching shear capacity of surface members, but to calculate the punching shear capacity of comparatively thin decks such as the reinforced concrete decks of highway bridges, the punching shear capacity equation[15] based on failure modes derived through testing can be applied, allowing the capacity to be derived with comparative accuracy. It is thought that this equation can also be used to calculate the punching shear capacity of members retrofitted with the upper surface overlaying method and lower surface overlaying method[16][17]. In such cases, design and construction for both overlaying methods must fulfill the considerations in Chapter 8 and both existing and retrofitted sections must form a composite structure that functions as a single unit. The material characteristics of the overlaying sections used for calculation should be values derived through appropriate testing as described in Section 3.4.4. In general, however, as the tensile strength and shear strength of overlaying reinforcing materials are greater than those of existing concrete, in most cases it is safe to use the strength properties of existing concrete to calculate the punching shear capacity. Currently the overlaying for the lower surface overlaying method is thinner than for the upper surface overlaying method and no mechanical construction methods have been established, so peeling of overlaying sections that is dependent on construction accuracy must be considered when evaluating the punching shear capacity.

9.2.4 Flexural Fatigue Capacity

The safety of the structure shall be verified by confirming that the retrofitted member does not experience flexural fatigue failure under load action and environmental action.

(1) External cable method

The flexural fatigue capacity shall be calculated with consideration given to the fatigue performance of the tension reinforcement in the existing sections, the internal cables and the concrete, as well as the fatigue properties of the external cables making up the members. The stress level caused by variable loads that create fatigue shall be calculated based on linear analysis consisting of such methods as direct modeling of external cables as chord members.

(2) Bonding and jacketing method and overlaying and jacketing method

Flexural fatigue capacity must be calculated with appropriate consideration given to the flexural fatigue performance of the existing sections as well as peeling fatigue failure and fatigue properties of reinforcing materials.

[Commentary]

(1) In general, the fatigue capacity of members reinforced with external cables is determined by the fatigue strength of the external cables, tension reinforcements, and internal cables or concrete that make up the members. Here, one method of calculating the stress level caused by variable loads has been shown as an index for verification of the fatigue capacity of members reinforced with external cables. One example of a method in which external cables are directly modeled as chord members is shown in the commentary for Section 9.3.3 (1), so this should be used as reference. When considering the fatigue of the tension reinforcement and internal cables or concrete in existing members, the history of stress levels caused by variable loads that have already been sustained before retrofitting must be considered.

Vibration of external cables is a problem specific to external cables. If the frequency of external cables in areas where they are not supported by deviators is near the frequency of the members, the vibration of the structure produced by the passage of vehicles or the like may cause the external cables themselves to resonate. If this happens, repeated bending stress may act on the external cables, and this can be predicted to reduce the fatigue capacity of the external cables, so the effect of this factor must be confirmed through vibration analysis or other appropriate methods to verify safety.

(2) When calculating the flexural fatigue capacity of bar materials to which reinforcing materials have been attached to the surface to which tension stress is applied, a study of the fatigue of reinforcing materials, steel in existing sections, and concrete, as well as a study of peeling fatigue failure of the reinforcing materials and the retrofitted members, must be performed. Also, when using mechanical anchor anchoring, a study of the fatigue strength of the anchor sections is needed as well. When considering the fatigue of the steel and concrete in existing members, the history of stress levels caused by variable loads that have already been sustained before retrofitting must be considered.

9.2.5 Shear Fatigue Capacity of Bar Members

The safety of the structure shall be verified by confirming that retrofitted bar members do not experience shear fatigue failure under load action and environmental action.

When the bonding and jacketing method is used, the shear fatigue capacity must be calculated with appropriate consideration given to the shear fatigue characteristics of the existing sections as well as the fatigue characteristics and peeling fatigue failure of the reinforcing materials.

[Commentary]

When mechanical anchor anchoring is used, the fatigue strength of the anchor sections must also be studied. When considering the fatigue of the shear reinforcements in the existing sections, the history of stress levels caused by variable loads that have already been sustained before retrofitting must be considered.

9.2.6 Punching Shear Fatigue Capacity of Surface Members

The safety of the structure shall be verified by confirming that surface members do not experience punching shear fatigue failure under load action and environmental action.

When the bonding method and concrete overlaying method is used, the punching shear fatigue capacity must be calculated with appropriate consideration given to the punching shear fatigue characteristics of the existing sections as well as fatigue breakage and peeling fatigue failure of reinforcing materials.

[Commentary]

According to the results of past tests, with the bonding method, attaching reinforcing materials to the surfaces to which tension stress is applied lengthens the fatigue life of surface members. It was decided that appropriate methods must be used to derive values when considering the effect of such retrofitting method. When anchors are anchored mechanically, a study must be made of the fatigue strength of the anchor sections as well.

It has been confirmed that, with the upper surface overlaying method, adding thickness to the deck upper surface through steel fiber reinforced concrete (SFRC) increases fatigue resistance[16]. This is because the steel fibers prevent cracking in the deck upper surface and prevent deterioration caused by the scraping of cracked surfaces against one another. In Reference ¹⁶⁾, the static punching shear capacity equation for decks that have become like girders, with consideration given to the fatigue failure mechanism of actual reinforced concrete decks of highway bridges, in accordance with the punching shear capacity equation in Reference[15], is used to employ a fatigue capacity evaluation equation obtained through wheel load running tests in order to estimate the fatigue capacity of overlaying decks. Here, based on test results, it is thought that no cracking will occur in overlaying sections up to just before final shear failure and that in overlaying sections the entire section is effective. Accordingly, the material characteristics for the overlaying concrete are used for the shear strength of overlaying sections that resist shear force, while the material characteristics for the existing concrete are used for the tensile strength of existing sections that resist tensile force, in order to calculate punching shear capacity and apply it to existing *S-N* curves for reinforced concrete decks that have not been retrofitted and enable the fatigue life of overlaying decks to be estimated.

When considering the punching shear fatigue characteristics of existing sections, the history of stress levels caused by variable loads that have already been sustained before retrofitting must be considered.

9.2.7 External Cable Fretting Fatigue Capacity

The safety of the structure shall be verified by confirming that the external cables do not experience fretting fatigue failure under load action and environmental action.

The fretting fatigue capacity of the external cables must be calculated with consideration given to the stress level due to variable loads as well as the additional bending stress and the bearing stress in the external cables caused by deflection.

[Commentary]

Since stress fluctuations caused by loads are transmitted through anchorage sections or deviators along the entire length of the external cable, due consideration must be given to the fatigue capacity of the external cable at the anchorage sections and deviators. At the deviators in particular, fretting fatigue may be produced in the external cable by the wear, etc. caused by contact between the deflection components and the external cable, and the contact of bare external cables with one another, so a study of safety must be conducted.

In general, the fretting fatigue capacity of external cables tends to decrease as the additional bending stress and the bearing stress produced in the external cable along with deflection increase. Accordingly, these values must be considered to determine the deflection angle and bending radius of the external cables. Particularly in cases such as when there are restrictions on the locations at which the external cables can be placed, the deflection angle of the cables will be greater, so they should be suitably protected against wear, or the amount of stress fluctuation in the external cables must be suitably restricted. The bearing stress should be calculated with the equation (**Equation C1.2.2**) in the retrofitting method manual in Supplement I, in accordance with the bearing stress applied in the direction of the center of the deviator. The additional bending stress should be calculated with **Equation C9.2.1**.

$$s_b = (d \times E) / (2 \times R) \dots\dots\dots(\text{Equation 9.2.1})$$

where:

- s_b : Additional bending stress (N/mm²)
- d : Bare cable diameter of external cables (mm)
- E : Young's modulus of external cables (N/mm²)
- R : Bending radius (mm)

9.2.8 Ultimate Deformation

The safety of the structure shall be verified by confirming that the ultimate deformation of retrofitted members is greater than the response deformation under load action and environmental action.

Ultimate deformation shall be calculated in accordance with the method in Chapter 4 of the Standard Specification (Seismic Design) or other appropriate methods.

Response deformation shall be derived in accordance with the methods in Chapters 3 and 4 of the Standard Specification (Seismic Design).

[Commentary]

The safety of structures is verified by confirming that the members making up the structure will not experience failure. Methods to confirm this include the methods that use member load-bearing capacity described in Sections 9.2.1 through 9.2.7, as well as the method using ultimate deformation. Particularly under seismic action, failure cannot be adequately predicted with load-carrying capacity alone, so ultimate deformation and response deformation must be compared to study whether or not member failure will occur. Ultimate deformation and response deformation can be calculated using the same method as that shown in Section 9.4.1 of these (draft) guidelines. However, the limit value for deformation in Section 9.4.1 is used to consider restorability, so it will be equal to or smaller than the ultimate deformation discussed here. Therefore, when using a value derived in accordance with Section 9.4.1, a value equal to or on the safe side of this value should be used as the ultimate deformation value.

9.3 Verification of Serviceability

9.3.1 Stress Level

The serviceability of the structure shall be verified by comparing the limit value for stress level determined from the serviceability of the structure and the stress level produced by load action and environmental action.

(1) External cable method

The stress level produced in the concrete, reinforcing materials and prestressing materials in retrofitted member sections shall be calculated in accordance with Sections 7.2 and 10.4.1 (1) in the Standard Specification (Design), with consideration given to changes in the structural system before and after retrofitting.

(2) Bonding/jacketing method and overlaying/jacketing method

- (i) The stress level produced in concrete and steel in retrofitted member sections shall be calculated in accordance with Section 7.2 in the Standard Specification (Design).
- (ii) The permanent load applied to the structure since before retrofitting shall be calculated as the stress level in existing sections, while the increase in permanent load and variable loads after retrofitting shall be determined by calculating the stress level in the composite section formed by existing and retrofitted sections, and these values shall be together.

[Commentary]

- (1) The stress level of retrofitted members is calculated as the sum of the stress level caused by permanent loads applied since before retrofitting and the stress level caused by permanent loads and variable loads applied after retrofitting.

The stress level caused by permanent loads applied before retrofitting should be calculated in accordance with Sections 7.2 and 10.4.1 in the Standard Specification (Design), with appropriate consideration given to the cracking status. The stress level caused by permanent loads and variable loads applied after retrofitting should be calculated in accordance with assumptions 1 - 4 below, with the effect of the external cables considered.

- 1 The prestressing force of the external cables remains constant even if the applied force increases or decreases.
- 2 The effective depth of the external cables remains constant even if the concrete members are deformed.
- 3 External cables are an elastic body.
- 4 External cables are not considered in effective sections.

Assumptions 1 and 2 relate to the changes in effective depth of the external cables accompanying the increase in external cable strain and the deformation of concrete members. In verifying serviceability, since member deformation is generally thought to be in the minute deformation range, it was decided that the increase in external cable strain and change in effective depth caused by concrete member deformation need not be considered. Accordingly, the concrete stress level may be derived by ignoring the increased stress of external cables and assuming that eccentric axial force caused by effective prestressing force is being applied.

Assumption 3 was established because, when the tension stress level of the stressing members exceeds the elastic limit, a variety of problems occur, such as that structural analysis and the assumptions regarding the calculation of stress levels do not apply, and prestressing force can no longer be treated as external force. However, in the case of retrofitting, it is thought that at times the stress level acting on concrete, steel and internal cables will exceed the elastic limit stress level. In such cases, the stress level must be calculated with a method that can suitably evaluate the effect of this factor.

Assumption 4 was established because, in general, the impact of external cables on effective sections is thought to be comparatively minor. Accordingly, when the external cable method is not used in combination with other retrofitting methods such as the bonding and jacketing method, the existing sections may basically be thought of as the effective sections, even after retrofitting.

When retrofitting reinforced concrete members with external cables, and when retrofitting prestressed concrete members that permit cracking during the service life after retrofitting, the effect of relaxation of the prestressing cable, concrete creep, the effect of shrinkage and the effect of reinforcement constraints must be considered to calculate the stress level of the concrete and steel under permanent loads, as noted in the provisions regarding polymer reinforced concrete (PRC) structures in Section 10.4.1 of the Standard Specification (Design). Also, with prestressed concrete members, the fact that the effective tensile force of the internal cables will be reduced must also be considered.

- (2) The stress level restrictions in Section 7.3 of the Standard Specification (Design) are recommended as restrictions on the stress level under general load action.

When continuous fiber sheets are used, calculations of the stress level must consider the orientation of the reinforcing materials. When the reinforcing materials and the existing sections are bonded together, calculations of the stress level produced in the concrete, steel and reinforcing materials in member sections should be based on the following assumptions.

- 1 Fiber strain is proportional to the distance from the neutral axis of the section.
- 2 Concrete, steel and reinforcing materials are elastic bodies.
- 3 The tension stress of the concrete is ignored.
- 4 As a rule, the stress-strain curve for the concrete and steel is in accordance with Chapter 3 of the Standard Specification (Design).
- 5 The Young's modulus of the reinforcing materials is in accordance with Section 3.4 of these (draft) guidelines.

When bonding strength is not thought to exist between the reinforcing materials and the concrete, appropriate methods must be used to calculate their individual stress levels.

9.3.2 Crack Width

The serviceability of the structure shall be verified by comparing the restrictions on crack width established from structure serviceability and the width of cracking produced under load action and environmental action.

(1) External cable method

The width of flexural cracking in retrofitted structures shall be calculated in accordance with Section 7.4.4 in the Standard Specification (Design), with consideration given to the effect of prestressing by external cables.

(2) Bonding/jacketing method and overlaying/jacketing method

The effect of the reinforcing materials shall be considered when calculating flexural cracking widths.

[Commentary]

(1) When cracking during the service life after retrofitting is permitted, the flexural cracking width should be calculated for the tension reinforcements or internal cables at the location closest to the existing member concrete surface, using the normal flexural cracking calculation Equation shown in **Equation 7.4.1** in the Standard Specification (Design).

Values s_{se} and s_{pe} for the increase in steel stress level, shown in **Equation 7.4.1**, must be derived with consideration for both the stress status of the concrete and steel before and after retrofitting and the status of the occurrence of cracking. In other words, in member sections in which cracking has occurred before retrofitting, the value for increase s_{se} or s_{pe} is the sum of (1) the value for the steel stress level that is applied before retrofitting, minus that portion of the steel stress level when the concrete at the same location as the steel changes from compression to zero, and (2) the steel stress level caused by the load applied after retrofitting. In member sections in which cracking occurs after retrofitting, the value for the steel stress level due to load that is applied after retrofitting, minus that portion of the steel stress level when the concrete changes from compression to zero, is the value for increase s_{se} or s_{pe} .

(2) If the spacing of cracks in members to which reinforcing materials have been attached is the same as that in reinforced concrete members, the reinforcement stress level, determined through consideration for the effect of the reinforcing materials, may be used to evaluate a value on the safe side for the width of cracks in retrofitted members, in accordance with **Equation 7.4.1** in the Standard Specification (Design).

In general, cracking in members to which reinforcing materials have been attached is more widely distributed than that in members without reinforcing materials attached, and as a result the crack width is reduced. In uniaxial tensile tests of members reinforced with carbon fiber sheets, the crack width was almost exactly proportional to the average strain of the carbon fiber sheet and reinforcement, and was 0.3 - 0.7 times that of unretrofitted members just before the stage of reinforcement yield [18][19]. Accordingly, **Equation C9.3.1**, in which the crack width indicated by **Equation 7.4.1** in the Standard Specification (Design) is multiplied by the maximum crack ratio of 0.7, may be used to determine the flexural cracking width when the lower surfaces of beams have been reinforced with continuous fiber sheets.

$$w = 0.7k[4c + 0.7(c_s - f)] \left[\frac{s_{se}}{E_s} \left(\text{or } \frac{s_{pe}}{E_p} \right) + e'_{cs} \right] \dots\dots\dots \text{(Equation C9.3.1)}$$

Since there is little data on cases in which steel plates have been used to reinforce the lower surfaces of flexural members, appropriate methods should be used to study the cracking width. Also, the mechanism by which shear cracking occurs and progresses differs from that of flexural cracking, so this should be studied using appropriate methods set forth elsewhere. In addition, studies of crack widths are not needed when reinforcing materials have been attached to the surfaces of concrete structures, since these surfaces have been protected.

When the overlaying and jacketing method has been used, the stress level derived for the composite section with the existing section and overlaying section bonded together may be used to evaluate the crack width in accordance with **Equation 7.4.1** in the Standard Specification (Design).

9.3.3 Displacement and Deformation

The serviceability of the structure shall be verified by comparing the restrictions on displacement and deformation determined from structure serviceability and the amount of displacement and deformation produced under load action and environmental action.

(1) External cable method

The displacement and deformation of retrofitted members shall be calculated as the sum of the displacement and deformation resulting from permanent loads applied before retrofitting, and the displacement and deformation resulting from permanent loads and variable loads applied after retrofitting. The displacement and deformation before and after displacement shall be calculated based on the methods shown below.

- (i) Calculation of the displacement and deformation before retrofitting shall be in accordance with Section 7.5.3 in the Standard Specification (Design).
- (ii) Calculation of the displacement and deformation after retrofitting shall be calculated in accordance with linear analysis, using methods such as direct modeling of external cables as chord members. As a rule, the decrease in rigidity due to cracking shall be considered when calculating the rigidity of concrete members used for analysis.

(2) Bonding/jacketing method and overlaying/jacketing method

Calculation of the displacement and deformation of retrofitted members shall be in accordance with Section 7.5.3 in the Standard Specification (Design).

[Commentary]

(1) The displacement and deformation due to permanent loads applied before retrofitting should be calculated in accordance with Section 7.5.3 in the Standard Specification (Design), with appropriate consideration given to the effect of decreased rigidity due to cracking and the progress of concrete creeping and drying shrinkage. However, when the variable loads applied before retrofitting are greater than the permanent loads, and the continuity and frequency of the variable loads are high, the effect of the history of variable loads must be considered in addition to the displacement and deformation due to permanent loads when calculating the displacement and deformation before retrofitting.

It was decided that the displacement and deformation of members reinforced with external cables should be calculated using linear analysis, through methods such as member evaluation with external cables directly modeled as chord members. As shown in **Figure C9.3.1**, the member evaluation methods involve applying variable loads to frame models with external cables modeled as chord members, and beams and virtual column members modeled as bar members, and directly deriving the variable stress level, etc. of the external cables. When the structure in question can be modeled as a two-dimensional model, this method enables calculation of the variable stress with comparative ease. However, modeling must appropriately model factors such as the characteristics of friction between the deflection components and the external cables.

When in actual practice it is not necessary to determine the precise displacement and deformation, and when it has been determined that no cracking will occur after retrofitting through calculations with the entire section effective, even members in which cracking has occurred before retrofitting can be considered members in which no cracking will occur, and the analysis can be conducted using the moment of inertia with the entire section effective.

(2) The displacement and deformation of retrofitted members must be calculated through evaluation with appropriate rigidity of the status of cracking in existing members. If the width of cracks occurring in existing members is great, generally the cracks are filled as surface treatment before retrofitting. The effect of this factor must be considered when calculating the displacement and deformation of retrofitted members.

With the lower surface overlaying method, the thickness is added on the tension side of existing members, so existing cracks are constrained and, until cracking occurs in the sections after retrofitting, the retrofitted sections appear to exhibit rigid section behavior and function with the entire section effective. After that point, as the load increases, the rigidity of the retrofitted section approaches the behavior of reinforced concrete sections in which the tension side concrete is ignored, and so the equation (**Equation C7.5.7**) in the Standard Specification (Design) holds true for section rigidity after lower surface thickness addition as well. Accordingly, it was thought that, when calculating displacement and deformation, this equation can be used

for calculation by performing numerical integration in the axial direction, and so it was decided that the process should be in accordance with Section 7.5.3 in the Standard Specification (Design).

In general, if it has only been a few years since the structure was built, it is possible that additional displacement and deformation will occur due to concrete shrinkage, creep and so on. In such cases, the additional displacement and deformation must be appropriately evaluated and added.

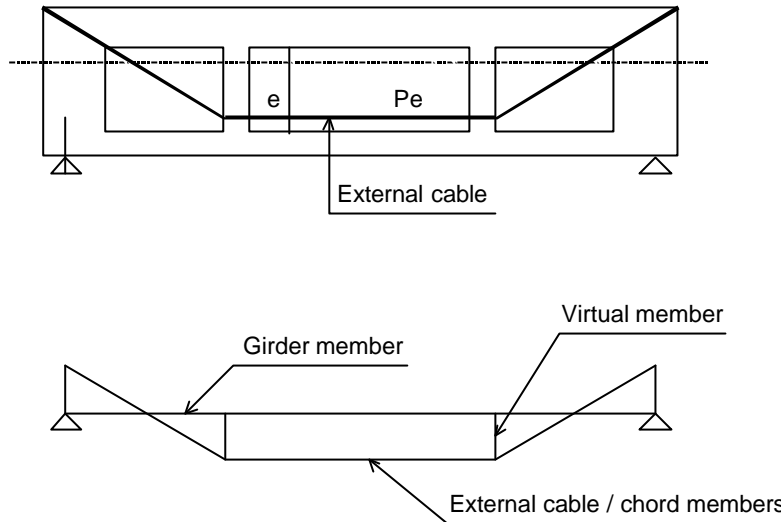

Figure C9.3.1 Structural analysis model using member evaluation method

9.4 Verification of Restorability

9.4.1 Deformation

The restorability of the structure shall be verified by confirming that the restrictions on deformation determined from the restorability of retrofitted members are greater than the response deformation under load action and environmental action. Here deformation shall refer to major deformation when load is applied or residual deformation after load application.

The restrictions on deformation determined from the restorability of retrofitted members shall be established in accordance with the method in Chapter 4 of the Standard Specification (Seismic Design) or other appropriate methods.

The response displacement shall be determined in accordance with the methods in Chapter 3 and Chapter 4 of the Standard Specification (Seismic Design).

[Commentary]

In calculating the response displacement, ductility ratio and residual displacement of the structure with respect to an earthquake, the structure must be appropriately expressed by means of a model, and the material characteristics must be modeled such that its dynamic properties are recreated. If no failure criteria have been incorporated into the analysis model, the failure mode of the constituent materials must be determined; flexural load-carrying capacity and shear capacity should be calculated in accordance with Sections 6.2.1 and 6.3.3 of the Standard Specification (Design) if the member is a non-retrofitted member and in accordance with Sections 9.2.1 and 9.2.2 of these (draft) guidelines if the member is a retrofitted member.

In domains with members where the use of plastic hinges is assumed, the deformation performance of structures is ensured by placing the reinforcing materials at right angles to the member axis and jacketing if many are used. For design evaluations, the method of applying ductility as a function of the flexural shear capacity ratio of the member in the plastic hinge domain, and the method of introducing the stress-strain relationship of concrete restrained in the plastic hinge domain to calculate the ultimate flexural deformation,

are used; the method is selected to match the characteristics of the structure (size, type, etc.). The retrofitting methods covered in these (draft) guidelines also use similar retrofitting methods; at present, the evaluation method for the former method is primarily member testing with the flexural shear capacity ratio as a parameter, while for the latter an evaluation method is being constructed through the introduction of the stress-strain relationship by means of axial compression tests.

In the commentary for Section 4.2 of the Standard Specification (Seismic Design), ductility is provided by **Equation C4.2.2** in the range of $V_{cd}/V_{mu} \leq 1.4$ and $V_{sd}/V_{mu} \leq 1.4$. For $V_{yd}/V_{mu} \geq 2.0$, the failure mode is stable bending failure, and for ordinary members having axial compression stress of approximately 1.0 N/mm^2 , concrete stress of $20 - 30 \text{ N/mm}^2$ and reinforcement yield strength of $300 - 400 \text{ N/mm}^2$, the ductility will be approximately 10. In material tests, when the ductility exceeds approximately 10, an increase in the amount of shear reinforcement tends not to have a notable effect on increased ductility, resulting in cases such as a history of repeated loads causing the reinforcement to break due to low cycle fatigue[20][21]. In the case of retrofitted columns as well, as shown by the example in **Figure C9.4.1**, in each of the test results[22][23] for steel plate jacketing and reinforced concrete jacketing (using PCa molds with steel fibers) and carbon fiber sheet retrofitted columns, conspicuous retrofitting effectiveness is apparent up to member angles of approximately 0.05.

The effect of ductility retrofitting differs depending on the characteristics of the retrofitting method, and the calculation equations are also different. Particularly with methods that use materials for which existing shear capacity equations cannot be applied, the characteristics of the method will be related to shear capacity equations and ductility calculation equations, so it is important to note that the form will differ from the **Equation C4.2.2** in the Standard Specification (Seismic Design). Also, as can be seen in the examples in **Figure C9.4.1** using steel plates and the PCa mold with steel fibers, when reinforcing materials that have great flexural tension ductility are used continuously in the member axial direction, the effect of preventing inner concrete peeling in the plastic hinge domains is even more apparent above the maximum load-carrying capacity, and it should also be noted that in some cases the ultimate member angle will greatly exceed 0.05.

The following is an outline of the results of research for railway structures and highway structures regarding methods used to calculate deformation performance (or ductility) with jacketing methods. With railway structures, in each case ductility is provided in the form of an empirical formula for evaluating, on the safe side, the results of an alternating positive-negative load test using a mock-up column test piece[22][25-29]. Here, the equation used to calculate ductility for the jacketing methods using steel plates and concrete materials is one that uses functions for flexural shear capacity ratio and shear reinforcement steel ratio; in contrast, in the case of jacketing with new materials and other reinforcing materials, the equation is provided by only a function for flexural shear capacity ratio. In the case of highway structures, depending on the differences between retrofitting methods, a stress-strain curve [30][31] showing the side constraining effect of the concrete is applied and a fiber model is used to provide ultimate displacement.

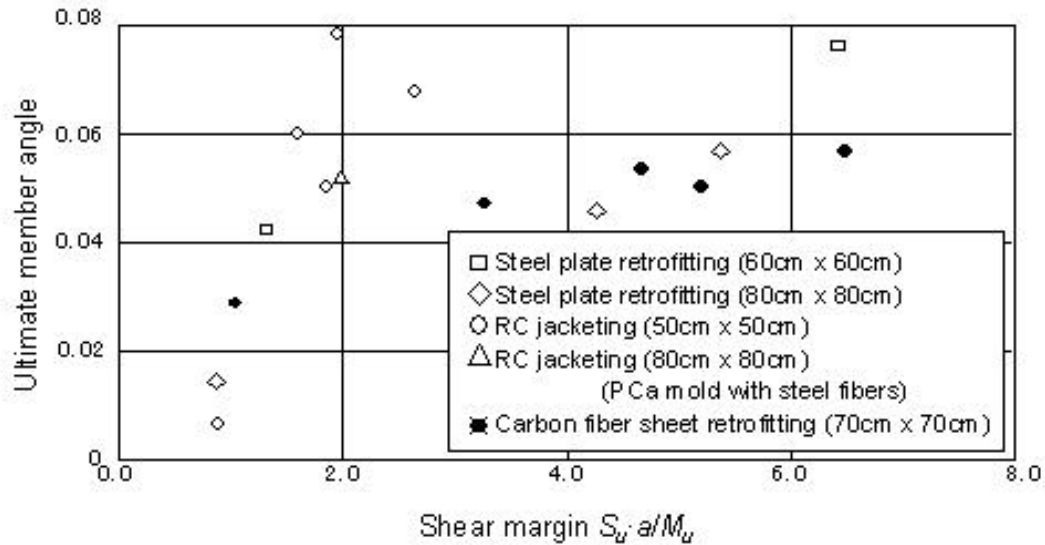

Figure C9.4.1 Example of the relationship between ultimate member angle and shear margin[24]

As an analytical approach to deformation performance of existing or retrofitted columns, it is thought that flexural deformation analysis using fiber models or methods using two-dimensional or three-dimensional non-linear finite element analysis can be used. Considerations that have been pointed out for the former analysis method using fiber models are the need for a stress-strain relationship exceeding the maximum stress of the concrete, a reinforcement stress-strain relationship that takes into account peeling and buckling of the concrete covering, and methods for accurate evaluation of member rotation due to the plastic hinge length and slippage[32]. Also, it has been reported that analysis using the finite element method (FEM), based on appropriate constitutive models and algorithms, enables direct evaluation of not only the occurrence and repetition of slipping and diagonal cracking in the reinforcement and reduction of shear resistance of the concrete due to major deformation, but also the effect of size in the tension softening domain, thus enabling accurate analysis of columns that experience stress failure after flexural yielding[33]. In addition, when three-dimensional structural laws are used, reflection of a concrete constraint effect due to the use of side reinforcing materials can also be anticipated[34].

In principle, it is possible to greatly reduce residual displacement by introducing prestressing in the outer axial direction of column members, and research is already being conducted to evaluate the results of introducing prestressing in the interior of sections on newly constructed bridge piers and the like[35][36]. Along with progress in future research relating to resilience capacity, energy absorption and deformation performance, a close watch should be kept on the applicability of the external cable method to seismic retrofitting of column members.

9.4.2 Stress Level

The restorability of the structure shall be verified by confirming that the restrictions on stress level determined from the restorability of retrofitted members are greater than the stress level under load action and environmental action.

(1) External cable method

The stress level of retrofitted members shall be calculated as the sum of the stress level caused by permanent loads applied before retrofitting and the stress level of permanent loads and accidental loads applied after retrofitting. The stress levels before and after retrofitting shall be calculated based on Section 9.3.1.

(2) Bonding/jacketing method and overlaying/jacketing method

The stress level for the permanent load applied since before retrofitting shall be calculated as the stress level in existing sections, while the stress level for the permanent load and accidental loads added after retrofitting shall be calculated for the composite section made up of the existing sections and retrofitted sections, and these values shall be added together.

[Commentary]

When the structure has sustained damage as the result of an earthquake or the like, if the residual displacement is in a small enough range, restoration of the structure's performance will be easy. The stress level of the reinforcement and tendon is generally in the elastic range, and if it can be determined that the structure is sufficiently safe with respect to concrete compressive damage, the residual displacement can be thought of as sufficiently minor. For this reason, it was decided that the stress level may be calculated as an index for verifying restorability. In such cases, the analysis model should be in accordance with the Standard Specification (Seismic Design). Also, calculation of the stress level should be done in accordance with Section 9.3.1 in these (draft) guidelines.

References

- [1] JSCE, "Standard Specification for Design and Construction of Concrete Structures (Design)", 1996. (In Japanese)
- [2] JSCE, "Standard Specification for Design and Construction of Concrete Structures (Construction)", 1996. (In Japanese)
- [3] JSCE, "Standard Specification for Design and Construction of Concrete Structures (Seismic Design)", 1996. (In Japanese)
- [4] JSCE, "Guidelines for Maintenance of Concrete Structures (Draft)", Concrete Library No.81, 1995. (In Japanese)
- [5] JSCE, "The Future of Retrofit Design and Construction for Concrete Structures - Retrofit Design Guidelines with Performance Verification (Draft)", Concrete Engineering Series No.28, 1998. (In Japanese)
- [6] Japan Concrete Institute, Kinki branch, "Midterm Report of the Technical Committee on Earthquake Disaster Countermeasures for Concrete Structures in Civil Engineering Field", 1995. (In Japanese)
- [7] Japan Concrete Institute, "Guidelines for Inspection and Repair of Crack in Concrete", 1992. (In Japanese)
- [8] Civil Engineering Research Center, "Technical Manual for Restoration of Concrete Structures Damaged by Earthquakes by the Ministry of Construction (Draft)", 1986. (In Japanese)
- [9] Road Association of Japan, "Manual for Repair and Rehabilitation of Road Bridges", 1979. (In Japanese)
- [10] Road Association of Japan, "Manual for Earthquake Disaster Countermeasures for Road Structures: Before-Earthquake Countermeasures", 1979. (In Japanese)
- [11] Hanshin Expressway Maintenance Technology Center, "Maintenance of Road Bridges in Examples of Damages and Restoration", 1993. (In Japanese)
- [12] Y.Ohama, et.al., "Countermeasures for Deterioration of Reinforced Concrete Structures", Techno Science, 1994. (In Japanese)
- [13] Japan Prestressed Concrete Engineering Association, "Standards for Design and Construction of External Cable Method and Precast Concrete Method (Draft)", pp.44-47, 1996. (In Japanese)
- [14] M.Sano and T.Miura, "A Study on a Design Method for Strengthening Concrete Members by Steel-Plate-Bonding", Journal of Materials, Concrete Structures and Pavements, JSCE, No.550/V-33, pp.117-129, 1996. (In Japanese)
- [15] Y.Maeda and S.Matsui, "Punching Shear Load Equation of Reinforced Concrete Slabs", Journal of Materials, Concrete Structures and Pavements, JSCE, No.348/V-1, pp.133-141, 1984. (In Japanese)
- [16] S.Matsui, et.al., "Evaluation of Durability of RC Slab Strengthened with Concrete Overlaying Method", Journal of Structural Engineering, Vol.38A, pp.1085-1096, 1992. (In Japanese)

- [17] T.Nagai, K.Kodama and K.Sato, "Experimental Study on under Repairing Method of Reinforced Concrete Slab", Proceedings of the Japan Concrete Institute, Vol.15, No.2, pp.341-346, 1993. (In Japanese)
- [18] H.Yoshizaki and Z.Wu, "Experimental Study on Crack Behavior of RC Tensile Members Strengthened with Carbon Fiber Sheets", Journal of Materials, Concrete Structures and Pavements, JSCE, No.613/V-42, pp.249-262, 1999. (In Japanese)
- [19] Z.Wu and H.Yoshizaki, "Analytical/Experimental Study on Composite Behavior in Strengthening Structure with Bonded Carbon Fiber Sheets", Proceedings of the Eighth Japan-US Conference on Composite Materials, pp.907-918, 1998.
- [20] H.Otsuka, et.al., "Experimental Study to Improve Ductility of RC Piers", Proceedings of the 51st Annual Convention of the JSCE, pp.1046-1047, 1996. (In Japanese)
- [21] M.Iwata, et.al., "Cyclic Loading Experiment of Reinforced Concrete Columns Strengthened with Hoop Bar, Outside of Established Reinforced Concrete Column", Proceedings of the Japan Concrete Institute, Vol.18, No.2, pp.167-172, 1996. (In Japanese)
- [22] Railway Technical Research Institute, "Design and Construction Guidelines for Seismic Retrofitting Method for Railway Viaduct Piers using Carbon Fiber Sheet", 1996. (In Japanese)
- [23] Y.Nakajima, et.al., "A Study for Strengthening of Reinforced Concrete Pier by Pre-cast Panel", Proceedings of JCI Symposium on Seismic Retrofitting Techniques for Concrete Structures, pp.229-236, 1997. (In Japanese)
- [24] Japan Concrete Institute, "Restoration and Seismic Retrofit of Concrete Structures and Their Examples", 1998. (In Japanese)
- [25] Railway Technical Research Institute, "Design and Construction Guidelines for Seismic Retrofitting Method for Viaduct Piers using Spray Mortar, 1996. (In Japanese)
- [26] Railway Technical Research Institute, "Design and Construction Guidelines for Seismic Retrofitting of Existing Concrete Railway Viaduct Piers, etc. - FRP Spraying Method", 1996. (In Japanese)
- [27] Railway Technical Research Institute, "Design and Construction Guidelines for Seismic Retrofitting of Existing Concrete Railway Viaduct Piers, etc. - Precast RC Mold Method", 1996. (In Japanese)
- [28] Railway Technical Research Institute, "Design and Construction Guidelines for Seismic Retrofitting of Existing Concrete Railway Viaduct Piers, etc. - Spiral Reinforcement Jacketing Method", 1996. (In Japanese)
- [29] Railway Technical Research Institute, "Design and Construction Guidelines for Seismic Retrofitting Method for Railway Viaduct Piers using Aramid Fiber Sheet", 1996. (In Japanese)
- [30] J.Hoshikuma, K.Kawashima and K.Nagaya, "A Stress-Strain Model for Reinforced Concrete Columns Confined by Lateral Reinforcement", Journal of Materials, Concrete Structures and Pavements, JSCE, No.520/V-28, pp.1-11, 1995. (In Japanese)
- [31] M.Hosotani, K.Kawashima and J.Hoshikuma, "A Stress-Strain Model for Concrete Cylinders Confined by Carbon Fiber Sheets", Journal of Materials, Concrete Structures and Pavements, JSCE, No.592/V-39, pp.37-52, 1998. (In Japanese)
- [32] JSCE, "Seismic Engineering for Concrete Structures – State of the Art and Future Scope", Concrete Engineering Series, No.20, 1997. (In Japanese)
- [33] X.An and K.Maekawa, "Shear Resistance and Ductility of RC Columns after Yield of Main Reinforcement", Journal of Materials, Concrete Structures and Pavements, JSCE, No.585/V-38, pp.233-247, 1998.
- [34] JSCE, "Technical Report of Subcommittee on Constitutive Models", Concrete Engineering Series, No.21, pp.101-111, 1997. (In Japanese)
- [35] T.Ito, T.Yamaguchi and S.Ikeda, "Flexural Deformation of Concrete Pier Prestressed in Axial Direction", Proceedings of the 7th Symposium on Development in Prestressed Concrete, pp.71-76, 1997. (In Japanese)
- [36] S.Ikeda, T.Mori and T.Yoshioka, "The Experimental Study on the Seismic Performance of Prestressed Concrete Piers", Journal of Prestressed Concrete, Vol.40, No.5, pp.40-47, 1998. (In Japanese)