

**CECAR IV**  
**June 25, 2007 Taipei**



**Working toward Asian Sustainability**

# **Restoration of Japan's Environment after the High Economic Growth**

**Case Studies on Urban-landscape**

**ISHII, Yumio Dr. Eng.**

**President, JSCE**

**Chairman, CTI Engineering**

# Mt. Fuji, the Spiritual Symbol of Japanese People is surrounded by Chemical Plants



Courtesy:美しい景観を創る会



**A beach on the Japan Sea protected by concrete blocks used to be covered with white sand and green pines**

Courtesy:美しい景観を創る会



# Tokyo Metropolitan Highway and used-to a shopping mall



Courtesy:美しい景観を創る会



## Urban sprawl near Tokyo for residential area

Courtesy:美しい景観を創る会



Kanda-gawa river, downtown Tokyo is merely a ditch, not a river.



Courtesy: CTI Engineering



## Nihom-bashi Bridge and River are covered by Highway constructed in '64 for Tokyo Olympics



Courtesy:美しい景観を創る会



**Biwako Water Supply Canal in Kyoto, 1890.  
A tourist spot and operative structure.**



Courtesy:美しい景観を創る会





**A National Heritage  
Kiyosu-bashi Bridge in downtown Tokyo, 1926  
withstood air raids in War II**

Courtesy:美しい景観を創る会



# A Symbol of Peace, Heiwa-Oohashi Bridge in Hiroshima Designed by Isamu Noguchi, a Japanese-American artist



Courtesy: CTI Engineering



**In 1963, Tomei Expressway was so designed as to reserve the scenery of Mt. Fuji.**

Courtesy:美しい景観を創る会



## The Furukawa river, eastern Tokyo, in '60s before restoration



Courtesy: CTI Engineering



# A Restoration Plan of urban river in '70s

Courtesy: CTI Engineering

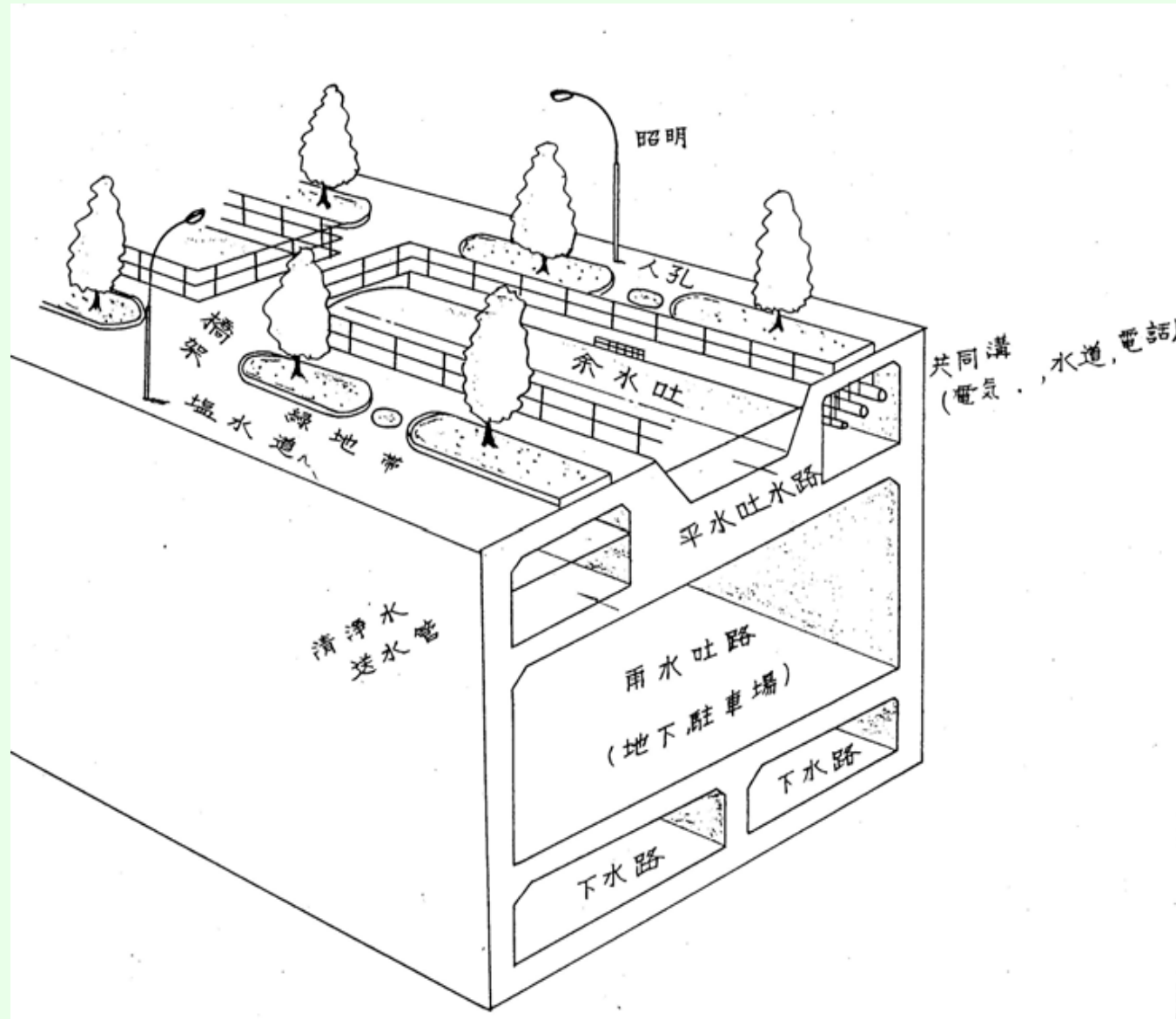

The Furukawa Shinsui River restores the river and the surrounding areas



Courtesy: CTI Engineering



**Nihom-bashi Bridge, Central Tokyo, in '30s before Highway Coverage  
constructed in 1911 as the Starting Milestone of National Road Network**



Courtesy: 日本橋總覽



## Nihombashi Bridge and River covered by Highway

Courtesy:美しい景観を創る会





## Cars, not Water, flow in the Tsukiji River, downstream of Ninom-bashi

Courtesy: CTI Engineering



# Restoration Project of the Nihonmm-bashi Bridge and Area, 2005

## Relocation of 2.2km Trunk Highway with 100,000 cars/day

Courtesy: 日本橋川に空を取り戻す会

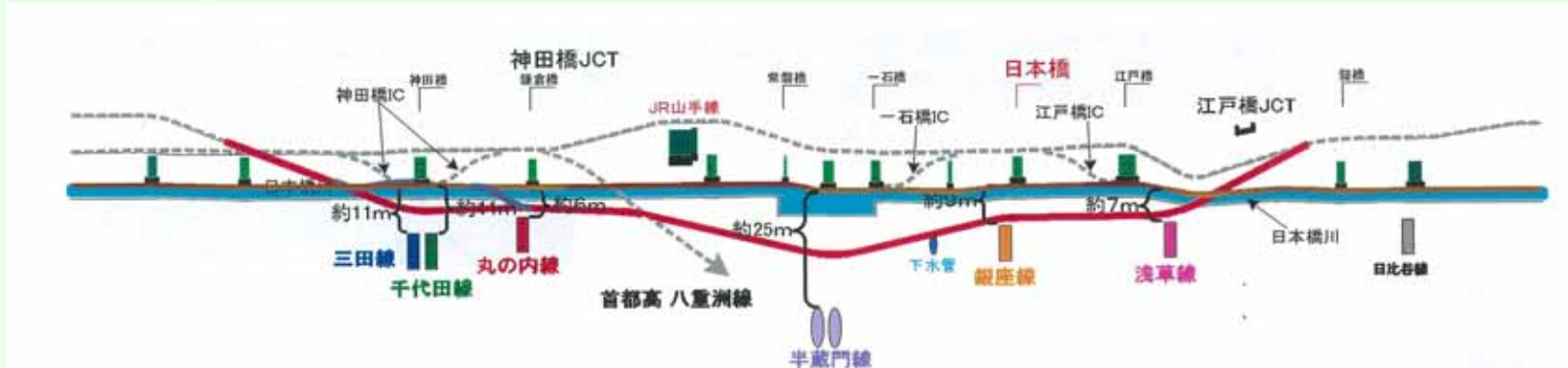

# Perspectives of the Restoration Project of the Nihom-bashi Area Proposal of Nihom-bashi Renaissance Committee

全体鳥瞰図（江戸橋方面から）



## Proposal of Nihom-bashi Renaissance Committee



# Perspectives of the Restoration Project of Nihom-bashi Bridge and Area

Courtesy: Nihimbashi Renaissance Committee



# Reconstructed Megane-bashi Bridge in Nagasaki



attracts numbers of tourists

Courtesy: CTI Engineering



# The Diversion Tunnel of Megane-bashi Restoration Project, Nagasaki

Courtesy: CTI Engineering



# Restoration of Momochi-hama Beach, Fukuoka by beach nourishing



Courtesy: CTI Engineering





# Restoration Plan of Iida-bori Moat and Kagurazaka shopping mall



Courtesy: JCCA



## Japanese Civil Engineers' Catch Phrase for Restoration:

- *Next Tokyo Olympics restore The Nihom-bashi Bridge degraded by the past Tokyo Olympics.*

# Restoration of Environment

## A key measure of Sustainable Development

JSCE will offer our experience to the colleagues  
for not to repeat the same **failure.**

**Thank You !**