

## PART III JSCE STANDARD

### TEST METHOD FOR DENSITY AND WATER ABSORPTION

### OF SLAG FINE AGGREGATE FOR CONCRETE

### BY MEASUREMENT OF ELECTRIC RESISTANCE

(JSCE-C506-2003)

#### 1. Scope

This standard covers test methods for density and water absorption of slag fine aggregate for concrete for which judgment of saturated surface-dry condition is expected to be difficult by the method using a flow cone described in JIS A 1109.

**Remark:** Slag aggregates for concrete, such as blast-furnace slag fine aggregate, ferronickel slag fine aggregate, copper slag fine aggregate and electric arc furnace oxidizing slag fine aggregate, include those having particles of various shapes ranging from spherical to angular or with extraordinarily unbalanced grading. For this reason, judgment of saturated surface-dry condition using a flow cone in accordance with JIS A 1109 is difficult in many cases. The present test methods are useful for determining the density and water absorption of fine aggregate having unusual shapes and grading.

#### 2. Standards cited

The following standards form a part of this standard by being cited to in this standard. The latest editions of these reference standards shall be used.

JIS A 1109	Methods of test for density and water absorption of fine aggregate
JIS K 8150	Sodium chloride
JIS Z 1712	Oriented polypropylene films for packaging
JIS Z 1714	Biaxially oriented nylon films for packaging
JIS A 1125	Methods of test for total moisture content of aggregates and surface moisture in aggregates by drying

### 3. Apparatus and Reagent

#### 3.1 Balance

A balance having a capacity of 2 kg or more and sensitive to 0.1 g or better shall be used.

#### 3.2 Pycnometer

The pycnometer to be used for density testing shall be a marked or graduated glass container or a glass container with a ground (frosted) top edge. It shall be such that the fine aggregate test sample can be readily introduced and the volume content can be reproduced within  $\pm 0.1\%$ . The volume of the container filled to the calibration mark shall be at least 1.5 times but not greater than 3 times the space required to accommodate the test sample.

**Reference:** A calibration capacity of 500 ml is normally used.

#### 3.3 Analogue tester

An analog tester for measuring the electric resistance of fine aggregate shall be an analogue type tester with a capacity of approximately  $3000 \text{ k}\Omega^{(1)}$ .

**Note (1):** An analogue tester is specified, as it provides stable readings without excessive sensitivity to the fluctuation of resistance values.

#### 3.4 Container for measuring electric resistance

The container for measuring the electric resistance of fine aggregate shall be fabricated using a non-absorbent insulating material. It shall be an open-top box with inside dimensions of 40 by 40 by 100 mm as shown in Fig. 1. A 40 by 40-mm copper plate electrode shall be placed on each end of the box.

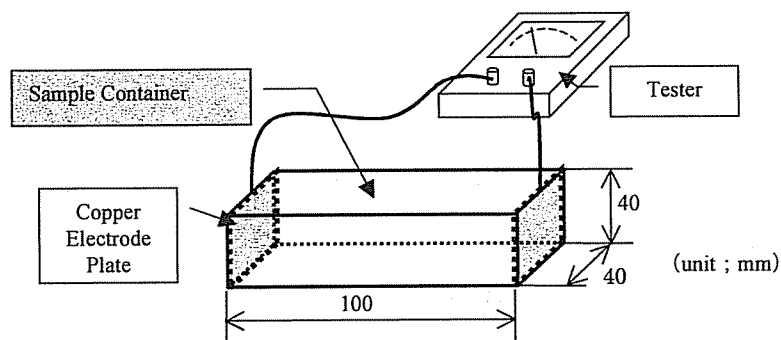

Figure 1 An Example of Container Measuring Electric Resistance

#### 3.5 Tamper

A mild steel tamper weighing  $1000 \pm 5 \text{ g}$  and having a flat square tamping face  $35 \pm 1 \text{ mm}$  each side shall be used.

### 3.6 Sodium chloride reagent

A guaranteed grade sodium chloride reagent conforming to JIS K 8150 shall be used<sup>(2)</sup>.

**Note (2):** Sodium chloride is added to stabilize the readings while measuring the electric resistance of fine aggregate test sample.

### 3.7 Container for agitation

A container for agitation shall be used for mixing fine aggregate with the sodium chloride reagent. It shall be a highly airtight container made of non-absorbent material and of a sufficient size to allow easy mixing.

**Remark:** A highly airtight container into which the fine aggregate test sample can be readily introduced is desirable.

Recommended containers include a 500-ml wide-mouthed glass reagent bottle with ground-in stopper and an airtight container made of polypropylene or polyethylene.

### 3.8 Moisture-retaining film

The moisture-retaining film for covering the container for measuring electric resistance after filling the test sample in the container shall conform to JIS Z 1712 or JIS Z 1714.

### 3.9 Dryer

The dryer shall have an exhaust slot and shall be capable of maintaining a temperature of  $105 \pm 5^\circ\text{C}$ .

## 4. Sampling and preparation

### 4.1 Sampling

Sampling shall be carried out as follows:

- (a) A sample representing the material shall be obtained and reduced to nearly the required amount by quartering or using a sample splitter. The mass of a reduced sample shall be approximately 15 kg.
- (b) The sample shall be allowed to absorb water for 24 hours. The water temperature shall be maintained at  $20 \pm 5^\circ\text{C}$  for at least 20 hours during absorption.

### 4.2 Preparation of test specimen

Test specimens shall be prepared as follows:

- a) Spread the sample thinly on a flat surface exposed to a gently moving current of warm air, and stir frequently to secure homogeneous drying.
- b) Prepare test specimens for measuring the water absorption by obtaining at least 1200 g each of test specimens to be subjected to measurement of the moisture content and electric resistance. Obtain the specimens at three or more arbitrary levels of water content while free surface water is present and three or more arbitrary levels after the surface water is no longer present during the process of drying.

**Remark:** It is necessary that a test specimen with a water content level close to an air-dry condition is included.

- c) Prepare a test specimen of at least 2.0 kg for density testing with an arbitrary level of water content while surface moisture is present and keep the water content unchanged during storage.

## 5. Procedure

### 5.1 Water absorption

The procedure of water absorption testing shall be as follows:

- (a) Quarter the test specimen adjusted to an arbitrary level of water content to obtain approximately 300 g and determine the mass ( $m$ ) to 0.1 g. Then dry the specimen at  $105 \pm 5^\circ\text{C}$  to constant mass, allow to cool to room temperature in a desiccator and determine the mass ( $m_D$ ) to 0.1 g.
- (b) Obtain another quarter of approximately 300 g of the same moisture condition into the container for agitating, add approximately 5 g of NaCl reagent, mix the contents by shaking the container vigorously for approximately 1 min and allow to stand for approximately 3 min.
- (c) Shake the sample vigorously again to thoroughly mix the test specimen before filling into the container for measuring the electric resistance. Fill the test specimen into the container in three layers to the top edge. Compact each layer with a tamper by applying 15 strokes for each layer. Cover the top surface of the filled specimen with moisture-retaining film<sup>(3)</sup>.

**Note (3):** This is to protect the specimen of an arbitrary level of moisture content from drying during resistance measurement.

- (d) Measure the electric resistance of the test specimen ( $R_i$ ) with a tester.
- (e) Repeat the procedure from (a) to (d) for each of the specimens of at least six arbitrary levels of moisture content prepared in 4.2 (b).

### 5.2 Density

The density testing shall be carried out as follows:

- (a) Quarter the specimen in 4.2 (c) into portions of approximately 500 g and determine the mass of each portion ( $m_l$ ) to 0.1 g.
- (b) Use two portions for density testing. Use the other two portions for measuring the water content of the specimen ( $Z$ ) by the method described in JIS A 1125.
- (c) Fill a pycnometer with water to the calibration mark, and determine the mass of the pycnometer containing water ( $m_z$ ) to 0.1 g<sup>(4)</sup>.
- (d) Empty the pycnometer and fill it with a test specimen for density testing in (a) to the calibration mark.
- (e) Tilt and roll the pycnometer on a flat surface to eliminate all air bubbles. Then immerse the

pycnometer in a water tank with a temperature of  $20 \pm 5^\circ\text{C}^{(5)}$ .

- (f) After immersing the pycnometer in the water tank for approximately 1 h, add water to the calibration mark and determine the mass ( $m_3$ , total mass of the container, specimen and water) to  $0.1 \text{ g}^{(5)}$ . The difference between the temperatures of water in the pycnometer at the first and second measurements shall not exceed  $1^\circ\text{C}$ .

**Note (4):** When using a container with a ground (frosted) top edge, determine the mass with the cover or a frosted glass plate placed on the container. Measure the water temperature at the time of weighing.

**Note (5):** When using a container with a ground (frosted) top edge, the process of immersing in a water tank at  $20 \pm 5^\circ\text{C}$  may be omitted in the procedure from (d) to (f).

### 5.3 Number of tests

Density and water absorption testing shall be carried out twice using samples simultaneously obtained.

## 6. Calculation

### 6.1 Water content at an arbitrary moisture level and water absorption

The water content at an arbitrary moisture level and the water absorption of a test specimen shall be calculated as follows:

- (a) Calculate the water content of a test specimen prepared to an arbitrary moisture level ( $Z_i$ ) by the following equation and round off to the nearest 0.01:

$$Z_i = \frac{m - m_D}{m_D} \times 100$$

where,  $Z_i$  = water content (%),  $m$  = mass of test specimen before drying (g),  $m_D$  = mass of test specimen after drying (g)

- (b) Plot three or more electric resistance values in the surface-wet range and three or more values in the surface-dry range on a diagram in which the x axis (arithmetic scale) represents water content ( $Z_i$ ) and the y axis (common logarithmic scale<sup>(6)</sup>) represents electric resistance ( $R_i$ ). Approximate the relationship between the electric resistance and water content to a straight line for each of the surface-wet and surface-dry ranges.

**Note (6):** For samples with a significantly high fines content, an arithmetic scale for electric resistance may be easier for approximation to a straight line.

- (c) Determine the water content corresponding to the intersection point of these two straight lines as the water absorption in the saturated surface-dry condition ( $Q$ ). Round off the calculation result to the nearest 0.01.

**Reference:** This is because the moisture condition immediately before the upsurge in the electric resistance as the sample condition changes from wet to dry is assumed to be the saturated surface-dry condition.

(d) The average of two test values shall be taken as the water absorption.

## 6.2 Density

The density shall be calculated as follows:

(a) The density of a sample in the saturated surface-dry and absolutely dry conditions shall be calculated by the following equations and rounded off to the nearest 0.01.

$$d_s = \frac{m_s}{V_s} = \frac{\rho_w \cdot (1 + Q/100) \cdot m_1}{(1 + Q/100) \cdot m_1 - (1 + Z/100) \cdot (m_3 - m_2)}$$

$$d_D = \frac{d_s}{1 + Q}$$

where,  $d_s$  = density in saturated surface-dry condition ( $\text{g/cm}^3$ )

$m_1$  = mass of sample in wet condition (g)

$m_2$  = mass of pycnometer containing water to calibration mark (g)

$m_3$  = mass of pycnometer containing sample and water after eliminating all air bubbles entrapped between particles (g)

$m_s$  = mass of sample in saturated surface-dry condition in mass  $m_1$  (g)

$$m_s = \frac{(1 + Q/100) \cdot m_1}{1 + Z/100}$$

$V_s$  = apparent volume of sample in wet condition with a mass of  $m_1$  ( $\text{cm}^3$ )

$$V_s = \frac{(1 + Z/100) \cdot (m_2 - m_3) + (1 + Q/100) \cdot m_1}{\rho_w \cdot (1 + Z/100)}$$

$\rho_w$  = density of water at test temperature<sup>(7)</sup> ( $\text{g/cm}^3$ )

**Note (7):** The densities of purified water at 15, 20 and 25°C are 0.9991, 0.9982 and 0.9970  $\text{g/cm}^3$ , respectively.

$Q$  = water absorption obtained by water absorption testing (%)

$Z$  = water content of sample used for density testing (%)

$d_D$  = density in oven-dry condition ( $\text{g/cm}^3$ )

(b) The average of the two test values shall be taken as the density.

## 7. Precision

Individual test values shall not differ from the average by more than 0.01  $\text{g/cm}^3$  and 0.05% for density

and water absorption, respectively.

## **8. Report**

### **8.1 Mandatory report items**

Report shall include the following:

- (a) Type, appearance and source of aggregate
- (b) Date and time of sampling
- (c) Density in saturated surface-dry condition and oven-dry condition ( $\text{g}/\text{cm}^3$ )
- (d) Water absorption (%)
- (e) Temperature of water used in the test

### **8.2 Non-mandatory report items**

The following items shall be included in the report as required:

- (a) Diagram of relationship between electric resistance and water content used in water absorption testing
- (b) Electric resistance, water content and straight line approximation equations at high and low moisture contents
- (c) Moisture content of sample in density testing (%)
- (d) Mass of sample in saturated surface-dry condition in mass  $m_l$  (g)
- (e) Apparent volume of sample in mass  $m_l$  in saturated surface-dry condition ( $\text{cm}^3$ )